

Stock taking of the Existing Technologies
for the Potential Entrepreneurs of

PLASTIC SECTOR

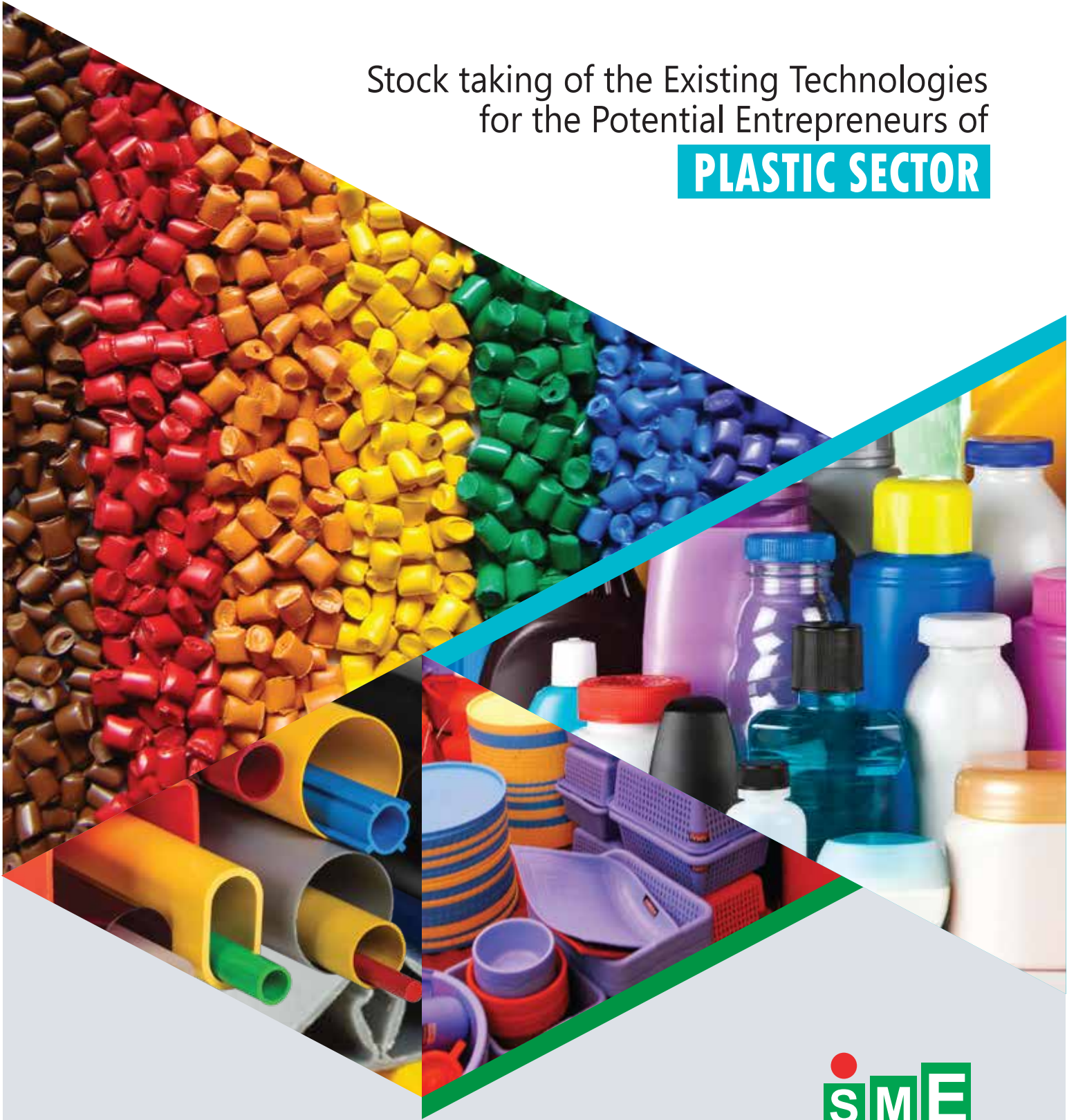

Small & Medium Enterprise Foundation

Stock Taking of Existing Technologies for the Potential Entrepreneurs of Plastic Sector

October 2017



Small & Medium Enterprise Foundation

Royal Tower, 4 Panthapath, Dhaka-1215, Bangladesh

Phone +8802 8142983, 9142907 Fax: +88028142467

E-mail: info@smef.org.bd, Website: www.smef.org.bd

Stock Taking of Existing Technologies for the Potential Entrepreneurs of Plastic Sector

Advisor

Md. Safiqul Islam
Managing Director, SME Foundation.

Editor

SM Shaheen Anwar
General Manager, SME Foundation.

Co-editor

Md. Tanvir Faisal
Assistant Manager, SME Foundation and
Salma Sultana
Assistant Manager, SME Foundation.

Reviewer

Dr. Nikhil Ranjan Dhar
Professor
Dept. of Industrial & Production Engineering
Bangladesh University of Engineering and Technology

Cover Design

Md. Monjurul Haque
Assistant Manager, SME Foundation

Published by:

Small & Medium Enterprise Foundation
Royal Tower, 4 Panthapath,
Kawran Bazar, Dhaka-1215.
Phone: +880-2-8142983, +880-2-9142907, Fax: +880-2-8142467,
E-mail: info@smef.org.bd; Website: www.smef.org.bd

ISBN: 978-984-34-2969-8

Price: BDT 300.

Foreword

Small and Medium Enterprises (SMEs) play a very crucial role in employment creation and overall economic development of any country. Among the formidable barriers encountered by SMEs access to technology is a prominent one. In a developing country like Bangladesh, SMEs have fallen behind in terms of awareness, adoption and adaptation of updated technologies which prominently describes the productivity enhancement and overall competitiveness of the enterprise.

SME Foundation is working as the apex organization in Bangladesh with the aim of promoting the growth of SMEs of manufacturing and service-oriented field of prioritized sectors of national economy declared by the National Industrial Policy 2016. In order to address the growing demands of technical information about prospective products and their production process from new and existing entrepreneurs, the SME Foundation has taken an initiative to develop sector-wise booklets and information stocks containing most basic technical information to develop any product. As a result, four publications from four priority sectors, i.e. i) Light Engineering Sector; ii) Plastic Sector; iii) Agro-Processing Sector and iv) Leather Sector have been prepared.

The sole purpose of this document is to facilitate entrepreneurs and/or potential investors by providing them with a general understanding of the prospective products, raw materials, required technology, necessary machineries, probable investment costs and broad description of sourcing ideas.

SM Shaheen Anwar
General Manager
SME Foundation

Disclaimer

The information presented in this publication provides only a generic collection of ideas on the selected subject. The data were collected from various reliable sources based on certain assumptions and may differ from case to case in real life situations. There is limited warranty on the correctness of the collected data/ information whence the publication has been faithfully reviewed by the expert on relevant subject matter. SME Foundation and its employees do not assume any liabilities resulting from any decision taken based on this document. The prospective users of this document are encouraged to undertake detail investigation, accumulate necessary information and consult professionals/ technical experts prior to taking any decisive action.

Acronym

BCPC	Bangladesh Central Product Classification
BDS	Bangladesh Standard
BGAPMEA	Bangladesh Garments Accessories and Packaging Manufacturers and Exporters Association
BPGMEA	Bangladesh Plastic Goods Manufacturers & Exporters Association
BSIC	Bangladesh Standard Industrial Classification
BSTI	Bangladesh Standards and Testing Institution
BTA	Bangladesh Tanners Association
CAD	Computer Aided Design
FOB	Free on Board
HS	Harmonized System
ISO	International Organization for Standardization
kW	Kilo Watt
RPM	Rotation per minute
SME	Small and Medium Enterprise
TPR	Thermoplastic Rubber

Table of Contents

1. Foreword.....	ii
2. Disclaimer.....	iii
3. Acronym	iv
4. Introduction: Plastic Sector of Bangladesh.....	vi
5. Chapter 1: Injection Molding.....	1
Product-01: Bucket	4
Product-02: Chair.....	6
Product-03: Sandal.....	8
Product-04: Toothbrush	11
6. Chapter 2: Blow Molding	15
Product-01: Bottle.....	19
Product-02: Agricultural Sprayer.....	22
Product-03: Toolbox	25
Product-04: Tricycle	28
7. Chapter 3: Extrusion	31
Product-01: Pipe.....	34
Product-02: Ballpoint Pen.....	38
Product-03: Film or Sheet	42
Product-04: Elastic Band	45
Product-05: Door Mat	48
8. Chapter 4: Rotational Molding	53
Product-01: Water Tank.....	56
Product-02: Traffic Barrier	59
Product-03: Ice Cooler.....	62
9. Chapter 5: Thermoforming	65
Product-01: Disposable Cup	70
Product-02: Packaging Tray.....	73
Product-03: Air Bubble Film	76
10. Chapter 6: Compression Molding.....	79
Product-01: Ceiling Rose.....	82
Product-02: Crockery.....	85
Product-03: Fuse Holder	89
11. Chapter 7: Miscellaneous Manufacturing Processes	92
Product-01: Button.....	93
Product-02: Spectacle Frame	98
Product-03: Smart Card	104
12. Annex-1: List of Products under Mandatory Certification Marks Scheme	i
13. Annex-2: Glossary of Plastic Terminology	vi

Introduction: Plastic Sector of Bangladesh

The history of plastic dates to 1284 by the first ever recorded mention of The Horners Company of London, with horn and tortoiseshell as the predominant natural plastic. The age of synthetic plastic started with the development of Casein plastic from milk in 1909. And plastic as an industry emerged in 1930 through the production of ‘Scotch’ tape, the first transparent sticky tape invented in United States of America by 3M company ^[1].

The plastics industry has emerged as one of the major strengths of the manufacturing sector of Bangladesh. The plastic industry, although comparatively new, began its journey in 1960s’ through the manufacturing of toys, bangles and photo frame using hand molds ^[2]. There are about 5,000 plastic industries in Bangladesh, of which 99% are SMEs. The plastic industries have shown about 20% growth per annum during the 1990s. The annual direct export is about Taka 700 crore and deemed export is about Taka 2,000 crore. The per capita consumption of plastic is 5 kg/year ^[3].

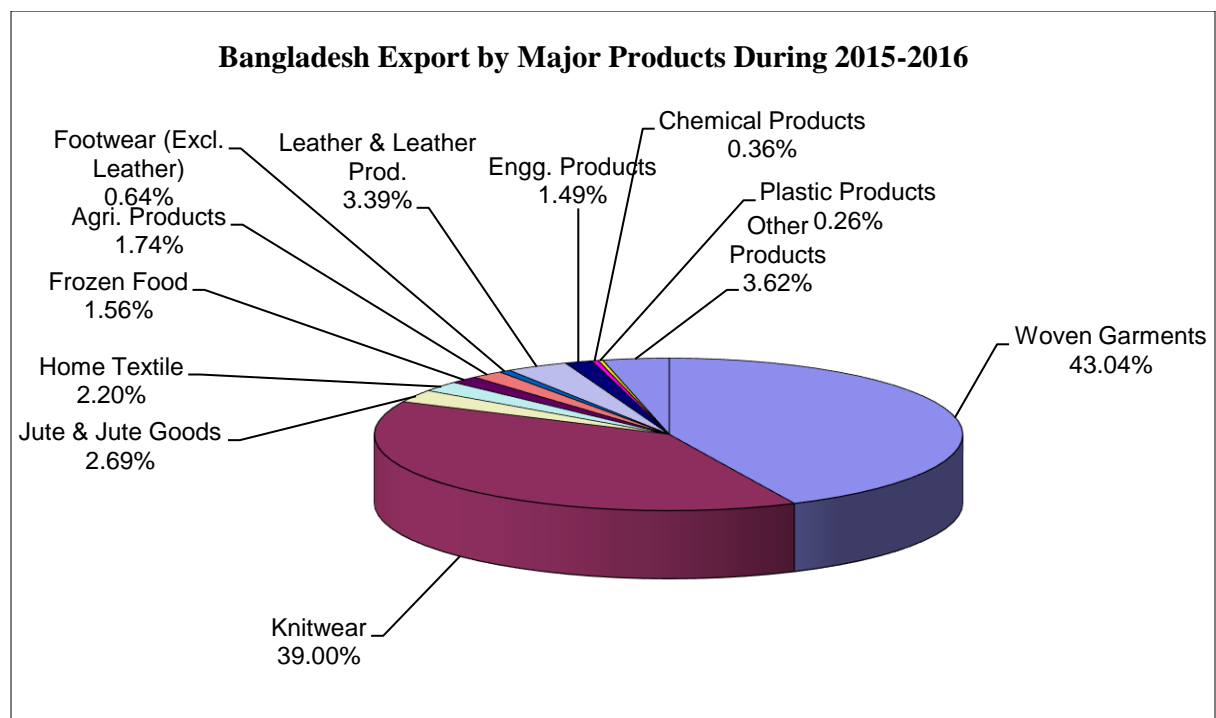

Figure i: Share of plastic products in annual export of Bangladesh during 2015-16 ^[4].

The above figure states the share (0.26%) of plastic product in annual export of Bangladesh during fiscal year 2015-16. The amount is about US Dollar 89 million out of total export of US Dollar 34.24 billion.

The export of plastic products has remained almost constant during last several years. The following figure illustrates the actual export income during last five fiscal year.

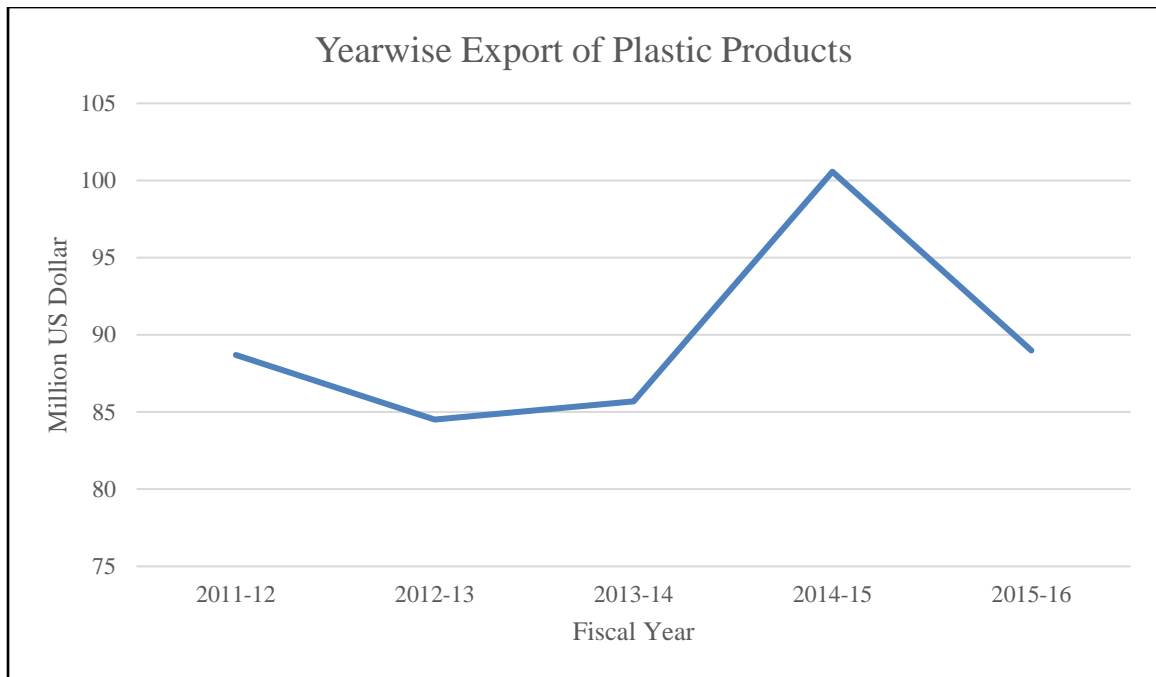

Figure ii: Annual export of plastic products from 2011-12 to 2015-16 ^[4].

References:

1. 'A History of Plastics'. http://www.bpf.co.uk/plastipedia/plastics_history/Default.aspx. Dated : 24 September 2017, 10:00am.
2. Islam, M. Serajul, 'Prospects And Challenges Of Plastic Industries In Bangladesh', Journal of Chemical Engineering, IEB, Vol. ChE. 26, No. 1, December 2011.
3. Jahan, S.M. and Khan, M.S.N., 'Achieving Global Value Chain Competitiveness- A Strategic Analysis of the Plastic Sector of Bangladesh', UN-ESCAP, 2009.
4. Export Promotion Bureau, Export Statistic Book, 2015-16.

Stock Taking of Existing Technologies
for the
Potential Entrepreneurs
of
‘Plastic Sector’

Chapter 1: Injection Molding

Injection Molding Process

Introduction

Injection Molding or Injection Moulding, is a manufacturing process for producing parts by injecting material into a mold. Injection molding can be performed with a host of materials mainly including metals, (for which the process is called die-casting), glasses, elastomers, confections, and most commonly thermoplastic and thermosetting polymers.

Plastic materials in the form of granule / pellet are placed in a hopper from which it is fed to a barrel / cylinder having a screw. The granules are heated to melt, mix and plasticize. A plunger forces the plastic into a mold cavity which is closed. The plastic cools and solidifies taking up the contour of the mold cavity. The mold is opened to remove the formed part which undergoes additional finishing operations as necessary. The injection molding can be performed both horizontally and vertically. A schematic of a horizontal injection molding machine is given below.

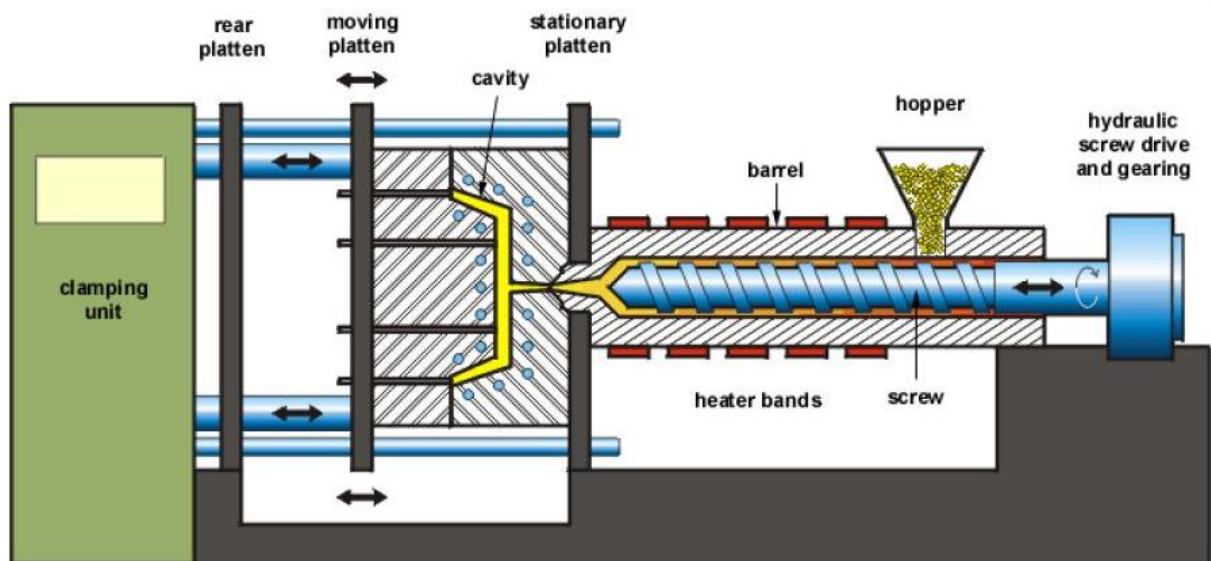

Fig. 1: Schematic representation of injection molding

Typical characteristics of injection molding:

- Most economic process for producing large quantity parts.
- Ideal for manufacturing parts of intricate shape with thin walled features.
- Capability to produce single molded part replacing assembly of multiple components.
- Possibility to incorporate inserts and multiple material in one process.

Possible defects and methods of elimination:

Sl.	Defect	Cause	Solution
1	Short Shot	<ul style="list-style-type: none"> • Insufficient material feed • Insufficient venting • Improper flow rate 	<ul style="list-style-type: none"> • Increase material feed • Add more venting in runner and gate • Increase flow rate and temperature

		<ul style="list-style-type: none"> • Inconsistent cycles 	<ul style="list-style-type: none"> • Apply streamlined product cycle
2	Flash	<ul style="list-style-type: none"> • Excessive injection pressure • Inadequate mold supports 	<ul style="list-style-type: none"> • Adopt optimal injection speed, pressure and temperature • Replace worn mold • Increase the clamp pressure and use large diameter support pillars
3	Sink	<ul style="list-style-type: none"> • Insufficient injection pressure or time • Excessive thickness • Excessive regrind use • Early gate opening 	<ul style="list-style-type: none"> • Increase pack and hold pressures and time • Decrease mold and melt temperature • Decrease wall thickness to minimum • Limit use of regrind to 10% – 15% • Highlight the importance of maintaining consistent cycles and use automatic cycle function
4	Warping	<ul style="list-style-type: none"> • Non-uniform cooling 	<ul style="list-style-type: none"> • Increase pack and hold pressures and time • Increase cooling time • Design mold with uniform wall thickness
5	Bubbles (Voids)	<ul style="list-style-type: none"> • Uneven solidification between surface and inner sections • Presence of moisture • Misalignment of mold halves 	<ul style="list-style-type: none"> • Locate gate at thickest part of molding • Dry material to suggested moisture levels • Increase holding pressure and time • Switch to a less viscous plastic • Ensure that mold parts are perfectly aligned

References:

- Bryce, Douglas M., “Plastic Injection Molding”, Volume IV, Society of Manufacturing Engineers, Dearborn, Michigan, USA, 1999.
- Wagner, John R., “Handbook of Troubleshooting Plastics Processes: A Practical Guide”, Wiley-Scrivener, 2012.
- Osswald, Tim A., Turng, Li-Sheng, Gramman, Paul J., “Injection Molding Handbook”, 2nd Edition, Hanser Gardner Publication, 2008.
- Rosato, D. V., “Injection Molding Handbook”, 3rd Edition, Springer, 2000.
- Isayev, Avraam I., “Injection and Compression Molding Fundamentals”, CRC Press, 2017.
- Potsch, Gerd, Michaeli, Walter, “Injection Molding: An Introduction”, 2nd Edition, Hanser Gardner Publication, 2008.
- Harper, Charles A., “Handbook of Plastics, Elastomers & Composites”, 4th Edition, McGraw-Hill Professional Publishing, 2002.

Injection Molded Products

Product-01: Bucket

Sub-sector: Household, Tableware & Kitchenware

HS-2007: 3924.90.90

BSIC-2009: 2220

BCPC-2011: 36940

Description:

A bucket or pail is a watertight vertical cylinder or truncated-cone having an open top, a closed flat bottom and attached with a semicircular carrying handle.

Product:



Raw Materials:

Base Raw Material:	<ul style="list-style-type: none"> High Density Polyethylene (HDPE) Low Density Polyethylene (LDPE) 	<ul style="list-style-type: none"> Polypropylene (PP) Polyvinyl Chloride (PVC)
Additives:	<ul style="list-style-type: none"> Process Aid and Mold Release 	<ul style="list-style-type: none"> Pigment

Raw Material Supplier:

- Bangladesh Polymer Importers' Association, 315/B, Tejgaon I/A, Dhaka. Tel: +8802-9830149.
- Bangladesh Chemical Importers and Merchants Association, 124, Hazaribagh, Dhaka-1209. Tel: +8802-8622608, +8802-8624009. Mobile: +8801986-842486.
- Bangladesh Paint Dyes & Chemical Merchants' Association, F.R.Plaza, 18, Imamganj, Dhaka-1100. Mobile: +8801755-651207, +8801711-938123, +8801819-074794.

Machineries and Specification:

1. Injection Molding Machine



- Shot Size (Volume/Weight): 1500cc/1500gm
- Injection Rate: ~ 350 gm/s
- Injection Pressure: ~ 150 MPa
- Clamping force: ~ 400 ton
- Mold Size (H x W): 600 x 600 mm
- Mold Thickness (Min-Max): 300-800 mm
- Power: ~ 50-60 kW (380V 3 Phase)
- Dimension (L x W x H): ~7m x 1.5m x 2.5m
- FOB Price: USD 50,000-60,000 (New)
- Gross Weight: 5-6 ton

2. Mixing Machine or Blending Machine



- Mixing Capacity: 100 kg/hr (250 l)
- Motor Power: ~ 2-4 HP
- Rotating Speed: ~ 90 rpm
- Power: 1 kW (400V 3 Phase)
- Dimension (L x W x H):~ .2m x0.8m x0.85m
- FOB Price: USD 500-1,500 (New)
- Gross Weight: 150-200 kg

Machineries Supplier:

- Bangladesh Hardware & Machinery Merchants' Association (BHMMA), 5, Bangabandu Avenue (3rd Floor), Dhaka. Tel: +8802-9569783. Mobile: +8801924-424085.
- China Bangla Engineers & Consultants Ltd. Mobile: +8801914-867929, +8801716-752370.

Production Process Flow Chart:

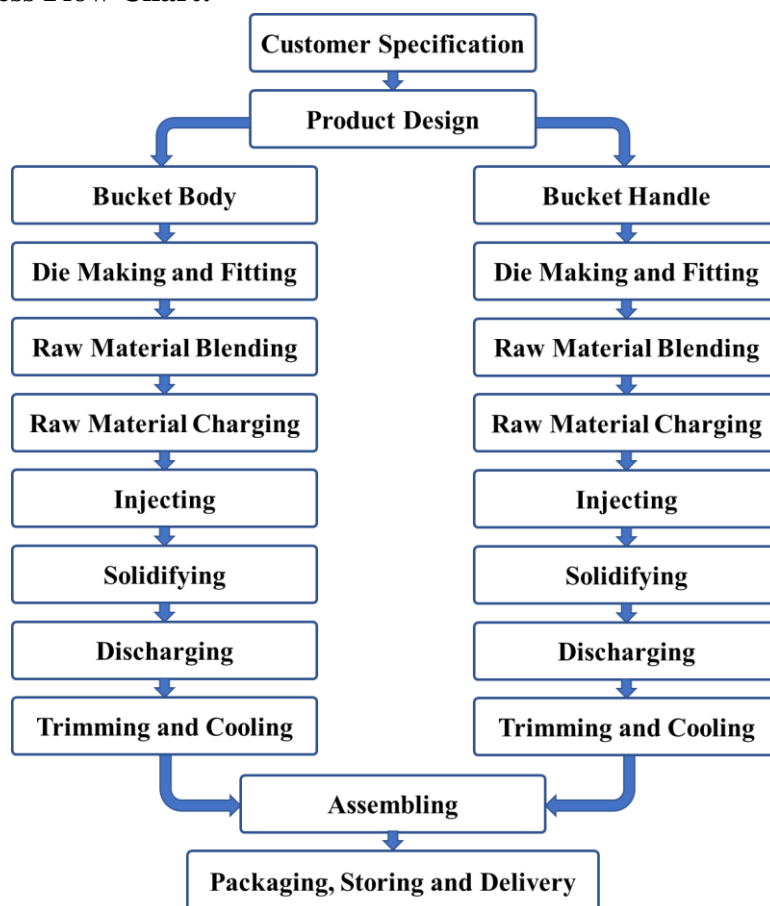

Die/Mold Supplier:

- Bangladesh Die & Mold Manufactures Association, 220, New Elephant Road, Dhaka. Tel: +8802-961545415. Mobile: +8801711-526913.

Bibliography:

- Bryce, Douglas M., "Plastic Injection Molding", Volume IV, Society of Manufacturing Engineers, Dearborn, Michigan, USA, 1999.
- Wagner, John R., "Handbook of Troubleshooting Plastics Processes: A Practical Guide", Wiley-Scrivener, 2012.

Product-02: Chair

Sub-sector: Furniture Ware

HS-2007: 9403.70.00

BSIC-2009: 3100

BCPC-2011: 38140

Description:

A chair is a furniture with a raised surface used for seating of one person. It has a one-piece, stackable and light-weight construction which is affordable and widely used across the world.

Product:



Raw Materials:

Base Raw Material:	<ul style="list-style-type: none"> • Polypropylene (PP) • High Density Polyethylene (HDPE) • Fiber Reinforced Plastic (FRP)
Additives:	<ul style="list-style-type: none"> • Process Aid and Mold Release • Pigment

Raw Material Supplier:

- Bangladesh Polymer Importers' Association, 315/B, Tejgaon I/A, Dhaka. Tel: +8802-9830149.
- Bangladesh Chemical Importers and Merchants Association, 124, Hazaribagh, Dhaka-1209. Tel: +8802-8622608, +8802-8624009. Mobile: +8801986-842486.
- Bangladesh Paint Dyes & Chemical Merchants' Association, F.R.Plaza, 18, Imamganj, Dhaka-1100. Mobile: +8801755-651207, +8801711-938123, +8801819-074794.

Machineries and Specification:

1. Injection Molding Machine



- Shot Size (Volume/Weight): 4000cc/3500gm
- Injection Rate: ~ 600 gm/s
- Injection Pressure: ~ 200 MPa
- Clamping force: ~ 1,000 ton
- Mold Size (H x W): 1,200 x 1,200 mm
- Mold Thickness (Min-Max): 500-1,200 mm
- Power: ~ 150 kW (380V 3 Phase)
- Dimension (L x W x H): ~12m x 3m x 3m
- FOB Price: USD 1,00,000-1,20,000 (New)
- Gross Weight: 50 ton

2. Mixing Machine or Blending Machine



- Mixing Capacity: 100 kg/hr (250 l)
- Motor Power: ~ 2-4 HP
- Rotating Speed: ~ 90 rpm
- Power: 1 kW (400V 3 Phase)
- Dimension (L x W x H):~ .2m x0.8m x0.85m
- Optional Feature: Timing Device, Heater, etc.
- FOB Price: USD 500-1,500 (New)
- Gross Weight: 150-200 kg

Machineries Supplier:

- Bangladesh Hardware & Machinery Merchants' Association (BHMMA), 5, Bangabandu Avenue (3rd Floor), Dhaka. Tel: +8802-9569783. Mobile: +8801924-424085.
- South Asia Trading. Tel: +8802-9667302, +8802-9667301.
- National World Export & Import (Pvt.) Co. Ltd. Mobile: +8801684-949001.

Production Process Flow Chart:

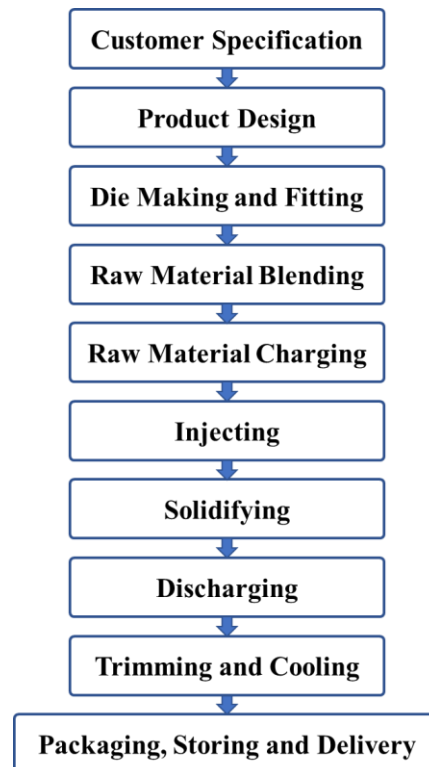

Die/Mold Supplier:

- Bangladesh Die & Mold Manufactures Association, 220, New Elephant Road, Dhaka. Tel: +8802-961545415. Mobile: +8801711-526913.

Bibliography:

- Bryce, Douglas M., "Plastic Injection Molding", Volume IV, Society of Manufacturing Engineers, Dearborn, Michigan, USA, 1999.
- Osswald, Tim A., Turng, Li-Sheng, Gramman, Paul J., "Injection Molding Handbook", 2nd Edition, Hanser Gardner Publication, 2008.

Product-03: Sandal

Sub-sector: Footwear

HS-2007: 6402.20.00

BSIC-2009: 1520

BCPC-2011: 29320

Description:

A Sandal or Flip-flop is a lightweight outdoor open type footwear consisting of a sole and straps assembled by means of plugging.

Product:



Raw Materials:

Base Raw Material:	<ul style="list-style-type: none"> Ethylene-vinyl Acetate (EVA) Polyvinyl Chloride (PVC)
Additives:	<ul style="list-style-type: none"> Process Aid and Mold Release Pigment

Raw Material Supplier:



- Bangladesh Polymer Importers' Association, 315/B, Tejgaon I/A, Dhaka. Tel: +8802-9830149.
- Bangladesh Chemical Importers and Merchants Association, 124, Hazaribagh, Dhaka-1209. Tel: +8802-8622608, +8802-8624009. Mobile: +8801986-842486.
- Bangladesh Paint Dyes & Chemical Merchants' Association, F.R.Plaza, 18, Imamganj, Dhaka-1100. Mobile: +8801755-651207, +8801711-938123, +8801819-074794.

Machineries and Specification:

1. Injection Molding Machine (Type 01)



- No. of Workstation: 6
- No. of Injector/Workstation: 1
- Shot Size (Volume/Weight): ~800cc/750gm
- Injection Pressure: ~ 65 MPa
- Clamping force: ~ 150 ton
- Mold Size (HxW): 350 x 500 mm
- Mold Thickness (Min-Max): 300-600 mm
- Power: ~ 60 kW (380V 3 Phase)
- Dimension (LxWxH):~6.5m x 1m x 3m
- FOB Price: USD 60,000-1,00,000 (New)
- Gross Weight: ~20 ton

2. Injection Molding Machine (Type 02)	
	<ul style="list-style-type: none"> • No. of Workstation: 20 • No. of Injector: 1 • Shot Size (Volume/Weight): ~750cc/700gm • Injection Pressure: ~ 60 MPa • Clamping force: ~ 60 ton • Mold Size (HxW): 250 x 400 mm • Mold Thickness (Min-Max): 200-300 mm • Power: ~ 30 kW (380V 3 Phase) • Dimension (LxWxH):~ 6.5m x 3.5m x 2m • FOB Price: USD 40,000-80,000 (New) • Gross Weight: ~15 ton
3. Mixing Machine or Blending Machine	
	<ul style="list-style-type: none"> • Mixing Capacity: 100 kg/hr (250 l) • Motor Power: ~ 2-4 HP • Rotating Speed: ~ 90 rpm • Power: 1 kW (400V 3 Phase) • Dimension (LxWx H):~ .2m x0.8mx 0.85m • Optional Feature: Timer, Heater. • FOB Price: USD 500-1,500 (New) • Gross Weight: 150-200 kg
4. Edge Trimming Machine	
	<ul style="list-style-type: none"> • Rotating Speed: ~5,000 rpm • Power: ~ 0.5 HP • Voltage: 220V • Dimension (LxWxH): ~ 1m x 0.5m x 1m • Optional Feature: Stitching, Beveling. • FOB Price: USD 150-250 (New) • Gross Weight: ~50 kg
Machineries Supplier: <ul style="list-style-type: none"> • Bangladesh Hardware & Machinery Merchants' Association (BHMMA), 5, Bangabandu Avenue (3rd Floor), Dhaka. Tel: +8802-9569783. Mobile: +8801924-424085. • South Asia Trading. Tel: +8802-9667302, +8802-9667301. • China Bangla Engineers & Consultants Ltd. Mobile: +8801914-867929, +8801716-752370. • Kulsum Enterprise. Mobile: +8801913-544816. • National World Export & Import (Pvt.) Co. Ltd. Mobile: +8801684-949001. • Osmonic BD Ltd. Tel: +8802-9571117, +8802-9563079. 	

Production Process Flow Chart:

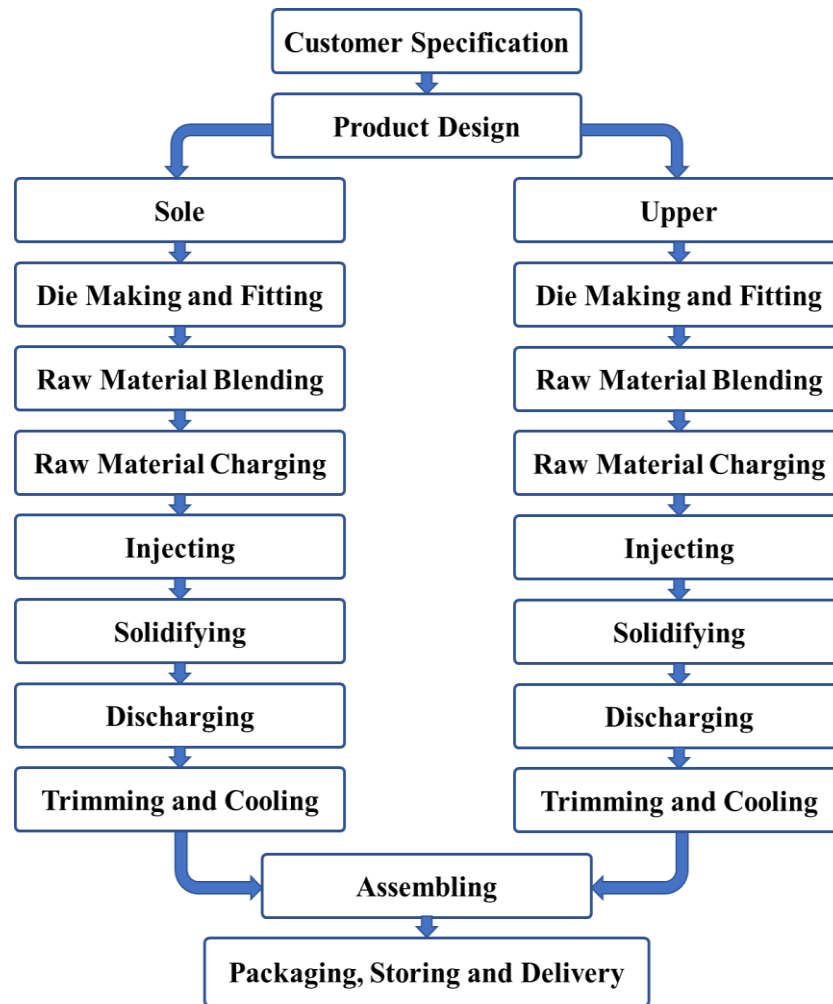

Die/Mold Supplier:

- Bangladesh Die & Mold Manufacturers Association, 220, New Elephant Road, Dhaka. Tel: +8802-961545415. Mobile: +8801711-526913.

Bibliography:

- Bryce, Douglas M., “Plastic Injection Molding”, Volume IV, Society of Manufacturing Engineers, Dearborn, Michigan, USA, 1999.
- Wagner, John R., “Handbook of Troubleshooting Plastics Processes: A Practical Guide”, Wiley-Scrivener, 2012.
- Osswald, Tim A., Turng, Li-Sheng, Gramman, Paul J., “Injection Molding Handbook”, 2nd Edition, Hanser Gardner Publication, 2008.

Product-04: Toothbrush

Sub-sector: Healthcare

HS-2007: 9603.10.00

BSIC-2009: 3290

BCPC-2011: 38993

Description:

A toothbrush is an oral hygiene instrument used to clean the teeth, gums, and tongue. It consists of a head of tightly clustered bristles mounted on a handle.

Product:



Raw Materials:

Base Raw Material:	<ul style="list-style-type: none"> • Polypropylene (PP) • Nylon Bristle 	<ul style="list-style-type: none"> • Thermoplastic Elastomers (TPE) • Thermoplastic Rubber (TPR)
Additives:	<ul style="list-style-type: none"> • Pigment 	<ul style="list-style-type: none"> • Process Aid and Mold Release

Raw Material Supplier:

- Bangladesh Polymer Importers' Association, 315/B, Tejgaon I/A, Dhaka. Tel: +8802-9830149.
- Bangladesh Chemical Importers and Merchants Association, 124, Hazaribagh, Dhaka-1209. Tel: +8802-8622608, +8802-8624009. Mobile: +8801986-842486.
- Bangladesh Paint Dyes & Chemical Merchants' Association, F.R.Plaza, 18, Imamganj, Dhaka-1100. Mobile: +8801755-651207, +8801711-938123, +8801819-074794.

Machineries and Specification:

1. Horizontal Injection Molding Machine



- Shot Size (Volume/Weight): 300cc/275gm
- Injection Rate: ~150 gm/s
- Injection Pressure: ~160 MPa
- Clamping Force: ~150 ton
- Mold Size (HxW): 300 x 400 mm
- Mold Thickness (Min-Max): 200-450 mm
- Power: ~25kW
- Dimension (LxWxH): ~5m x 1.5m x 2m
- FOB Price: USD 30,000-50,000 (New)
- Gross Weight: ~ 5 ton

2. Vertical Injection Molding Machine



- Shot Size (Volume/Weight): 50cc/45gm
- Injection Rate: ~35 gm/s
- Injection Pressure: ~160 MPa
- Clamping Force: ~30 ton
- Mold Size (HxW): 200 x 300 mm
- Mold Thickness (Min-Max): 100-200 mm
- Power: ~ 8 kW
- Dimension (LxWxH): ~2m x 1m x 2.5m
- FOB Price: USD 8,000-15,000
- Gross Weight: ~ 1.5 ton

3. Cutting Machine



- Knife Type: Circular
- Bundle Dia. (Min-Max): 35-80mm
- Bundle Length (Min-Max): Any-2m
- Puk Length (Min-Max): 20-400mm
- Cutting Rate: ~50 Pieces/min
- Power: ~ 2 kW
- Dimension (LxWxH): ~3m x 1.5m x 2m
- FOB Price: USD 3,000-7,000
- Gross Weight: ~ 1 ton

4. Tufting Machine



- Hole Field Area (LxW): ~ Max. 30x50mm
- Hole Size (Min-Max): 1.5-3.0mm
- Filament Color: 3
- Axes of Tufting: 1/2/3
- Tufting Rate: ~800-1,000 Tufts/min
- Power: ~ 3 kW
- Dimension (LxWxH): ~2m x 1m x 1.5m
- FOB Price: USD 15,000-30,000
- Gross Weight: ~ 1.5 ton

5. Finishing Machine (Trimming and End-rounding)



- No. of Finishing Stations: ~ 5
- No. of Units/Finishing Station: ~ 5
- Finishing Rate: ~ 50 Brushes/min
- Additional Features: Hot Stamping, Decal
- Power: ~ 5 kW
- Dimension (LxWxH): ~ 3m x 2m x 2m
- FOB Price: USD 18,000-35,000
- Gross Weight: ~ 2.5 ton

6. Mixing Machine or Blending Machine



- Mixing Capacity: 100 kg/hr (250 l)
- Motor Power: ~ 2-4 HP
- Rotating Speed: ~ 90 rpm
- Power: 1 kW (400V 3 Phase)
- Dimension (L x W x H):~ .2m x0.8m x0.85m
- FOB Price: USD 500-1,500 (New)
- Gross Weight: 150-200 kg

Machineries Supplier:

- Bangladesh Hardware & Machinery Merchants' Association (BHMMA), 5, Bangabandu Avenue (3rd Floor), Dhaka. Tel: +8802-9569783. Mobile: +8801924-424085.
- China Bangla Engineers & Consultants Ltd. Mobile: +8801914-867929, +8801716-752370.

Production Process Flow Chart:

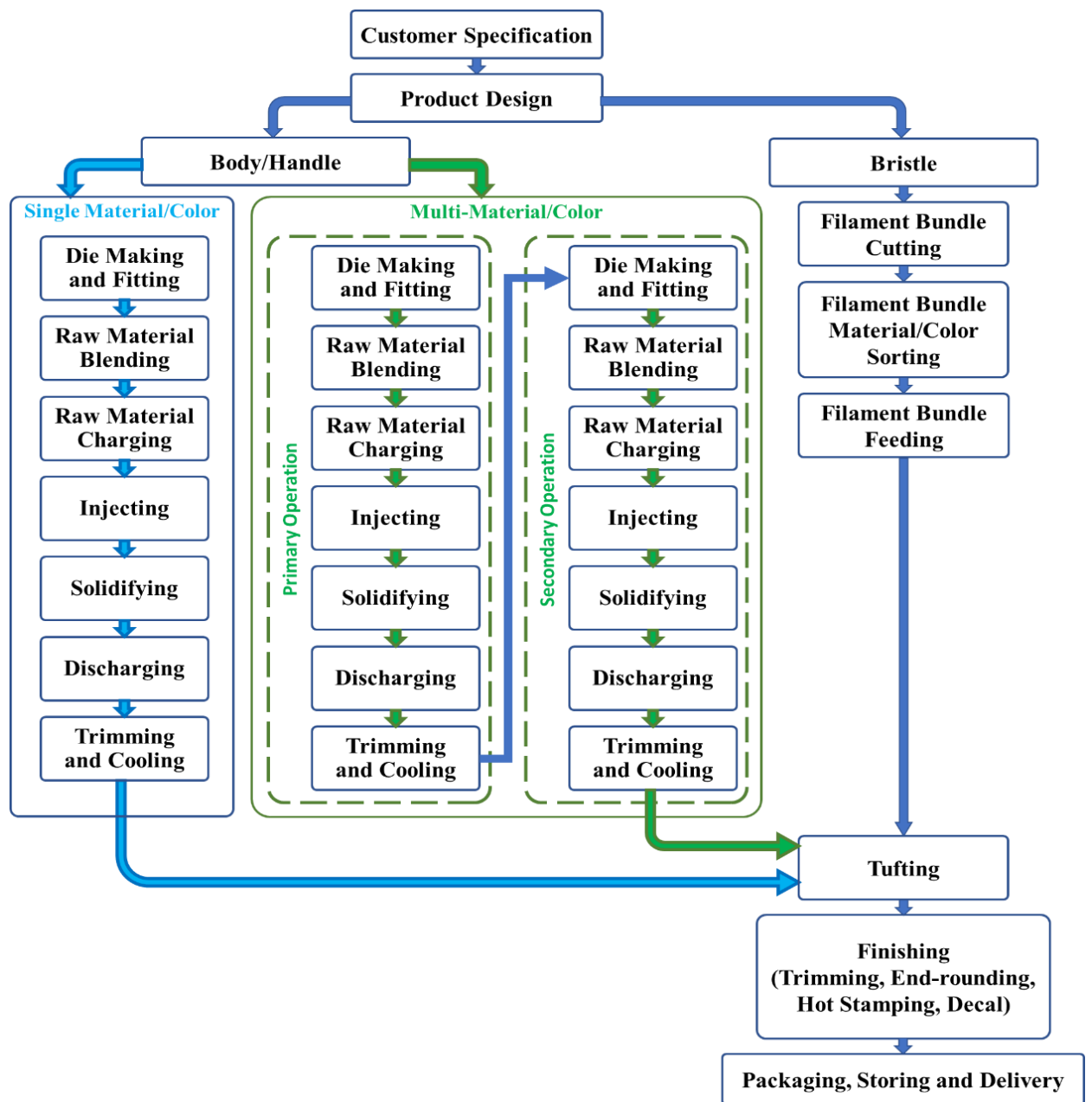

Die/Mold Supplier:

- Bangladesh Die & Mold Manufactures Association, 220, New Elephant Road, Dhaka.
Tel: +8802-961545415. Mobile: +8801711-526913.

Bibliography:

- Bryce, Douglas M., “Plastic Injection Molding”, Volume IV, Society of Manufacturing Engineers, Dearborn, Michigan, USA, 1999.
- Wagner, John R., “Handbook of Troubleshooting Plastics Processes: A Practical Guide”, Wiley-Scrivener, 2012.
- Osswald, Tim A., Turng, Li-Sheng, Gramman, Paul J., “Injection Molding Handbook”, 2nd Edition, Hanser Gardner Publication, 2008.

Chapter 2: Blow Molding

Blow Molding Process

Introduction:

Blow molding or moulding is a manufacturing process in which air pressure is used to inflate soft plastic into a mold cavity. Blow molding is accomplished in two steps: (1) fabrication of a starting tube of molten plastic, called a parison or preform; and (2) inflation of the tube to the desired final shape. Forming the parison or preform is accomplished by either of two processes: extrusion or injection molding.

The process begins with the heated parison or preform placed inside a split mold with a hollow cavity. The mold sides are then clamped together, pinching and sealing the parison or preform tube. Air is blown into the tube, which expands the hot resin wall into the shape of the cavity; the mold is cooled with water solidifying the resin into the shape of the part. Once cooled, the part is ejected from the mold and trimmed.

There are three main types of blow molding; i) Extrusion Blow Molding, ii) Injection Blow Molding, and iii) Stretch Blow Molding. Schematic representations of them are given below:

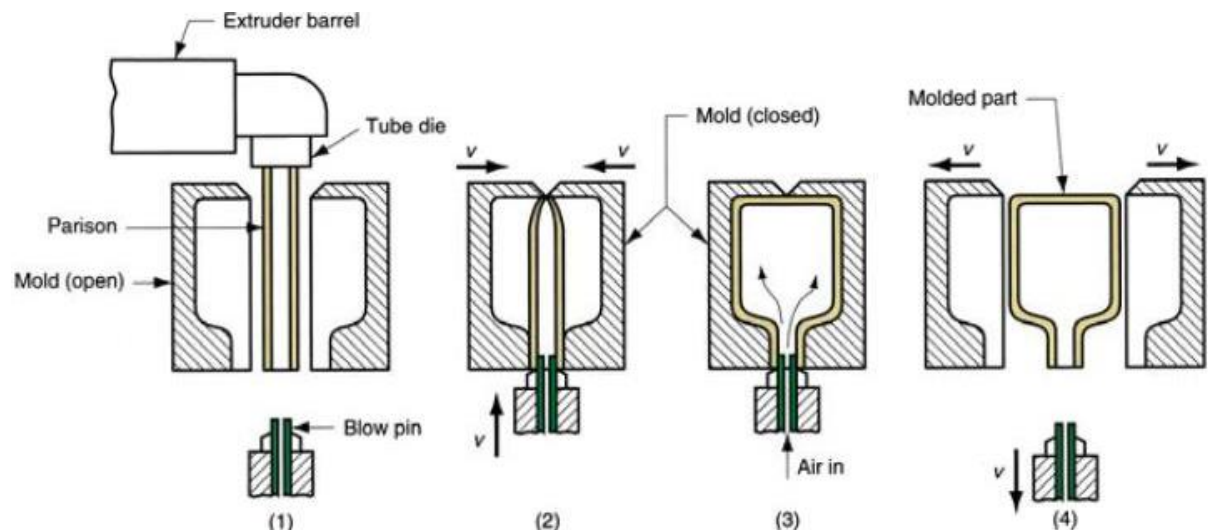

Fig. 2: Schematic representation of extrusion blow molding

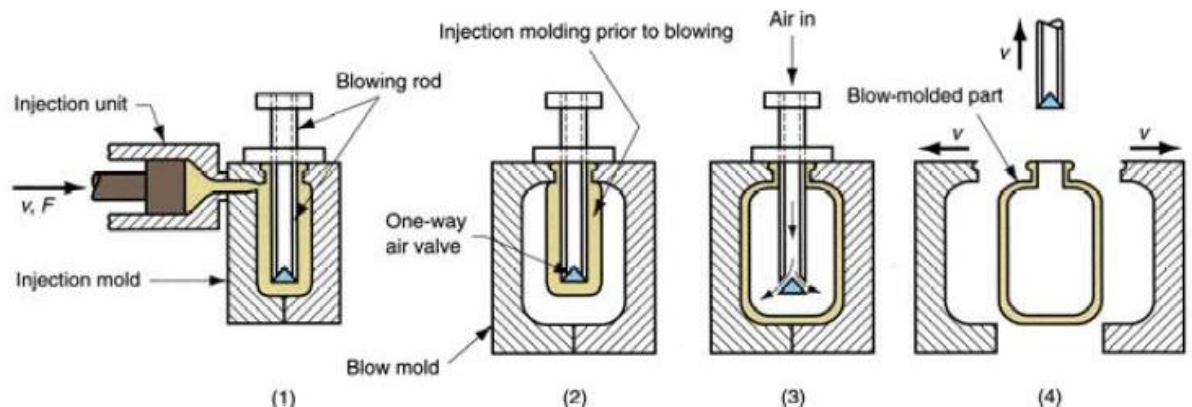

Fig. 3: Schematic representation of injection blow molding

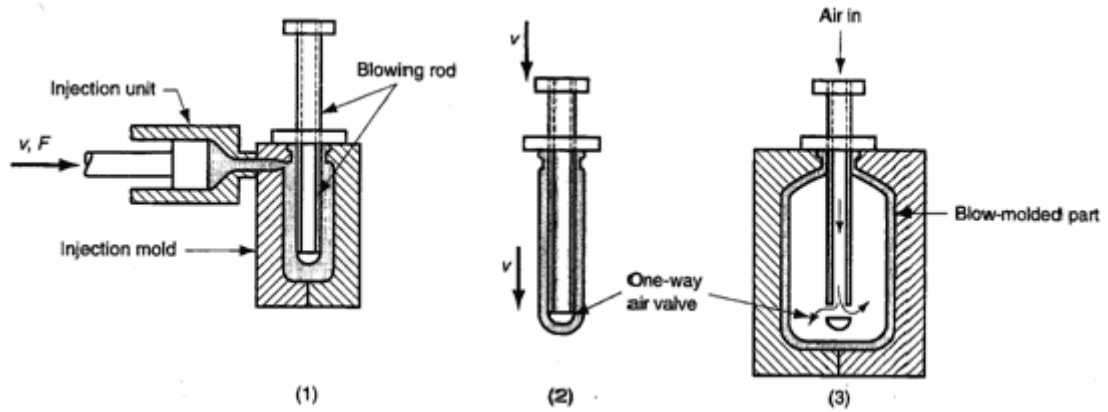

Fig. 4: Schematic representation of stretch blow molding

Typical characteristics of blow molding:

- It is limited to thermoplastic materials only.
- Most economic process for producing large quantity parts.
- Ideal for manufacturing parts of thin walled hollow shapes.
- Possibility to incorporate inserts and multiple material in one process.

Possible defects and methods of elimination:

Sl.	Defect	Cause	Solution
1	Rocker Bottoms	<ul style="list-style-type: none"> • Insufficient mold cooling • Excessive stock temperature • Improper part design 	<ul style="list-style-type: none"> • Increase cooling water flow and determine if this eliminates warpage • Eliminate cooling channel blockade • Incorporate properly designed cooling channel • Reduce stock temperature • Incorporate consistent material distribution and section thickness
2	Bubbles	<ul style="list-style-type: none"> • Presence of moisture • Overcooling in extruder throat • Misalignment of mold halves 	<ul style="list-style-type: none"> • Dry material to suggested moisture levels • Increase holding pressure and time • Switch to a less viscous plastic • Decrease water cooling at throat • Ensure that mold parts are perfectly aligned
3	Cold Spots	<ul style="list-style-type: none"> • Difference in melting index of resins • Inconsistent melting 	<ul style="list-style-type: none"> • Use material with close difference in melt index • Ensure proper extrusion conditions
4	Thinning	<ul style="list-style-type: none"> • Excessive stock temperature • Too short or too sharp pinch-off land length • Excessive pre-blow or high pressure 	<ul style="list-style-type: none"> • Decrease stock temperature • Adjust pinch-off land length • Delay pre-blow conditions

5	Tearing	<ul style="list-style-type: none"> • Long pinch-off land length • Worn pinch-off • Mold mismatch • Mold damage • Uneven clamping pressure 	<ul style="list-style-type: none"> • Minimize weld to eliminate improper mold closing • Balance between strong weld and trimmable pinch-off • Correct temporarily by rolling them back; refurbishing is necessary • Replace worn locating pins • Fill and regrind mold damages • Adjust clamping pressure
6	Cutting	<ul style="list-style-type: none"> • High stock temperature • Excessive fast mold closing 	<ul style="list-style-type: none"> • Reduce stock temperature • Control mold closing cycle and parameters

References:

- Rosato, Dominick V., Rosato, Andrew V., DiMattia, David P., “Blow Molding Handbook: Technology, Performance, Markets, Economics: The Complete Blow Molding Operation”, 2nd Rev. Edition, Hanser Publications, 2004.
- Lee, Norman C., “Plastic Blow Molding Handbook”, Springer, 1990.
- Brandau, Ottmar, “Stretch Blow Molding”, 3rd Edition, William Andrew, 2016.
- Lee, Norman C., “Understanding Blow Molding”, 2nd Edition, Hanser Gardner Publications, 2007.
- Belcher, Samuel L., “Practical Extrusion Blow Molding”, UK Edition, Marcel Dekker, 2017.
- Belcher, Samuel L., “Practical Guide to Injection Blow Molding”, CRC Press, 2007.
- Kazmer, David O., “Blow Molding Design Guide”, 2nd Edition, Hanser Gardner Publications, 2008.

Blow Molded Products

Product-01: Bottle

Sub-sector: Packaging

HS-2007: 3923.29.90

BSIC-2009: 2220

BCPC-2011: 36410

Description:

A bottle is a rigid/flexible container with a neck that is narrower than the body and a mouth. It is used for packaging of potable water, beverage, edible oil and liquid substances.

Product:



Raw Materials:

Base Raw Material:	<ul style="list-style-type: none"> • Polyethylene Terephthalate (PET) • Polypropylene (PP)
Additives:	<ul style="list-style-type: none"> • Process Aid and Mold Release • Pigment

Raw Material Supplier:

- Bangladesh Polymer Importers' Association, 315/B, Tejgaon I/A, Dhaka. Tel: +8802-9830149.
- Bangladesh Chemical Importers and Merchants Association, 124, Hazaribagh, Dhaka-1209. Tel: +8802-8622608, +8802-8624009. Mobile: +8801986-842486.
- Bangladesh Paint Dyes & Chemical Merchants' Association, F.R.Plaza, 18, Imamganj, Dhaka-1100. Mobile: +8801755-651207, +8801711-938123, +8801819-074794.

Machineries and Specification:

1. Horizontal Injection Molding Machine



- Shot Size (Volume/Weight): ~ 450cc/650gm
- Injection Rate: ~180 gm/s
- Injection Pressure: ~160 MPa
- Clamping Force: ~220 ton
- Mold Size (HxW): 400 x 450 mm
- Mold Thickness (Min-Max): 150-450 mm
- Power: ~28 kW
- Dimension (LxWxH): ~5m x 1.5m x 2m
- FOB Price: USD 45,000-60,000
- Gross Weight: ~ 6 ton

2. Stretch Blow Molding Machine



- Product Neck Dia. (Min-Max): 19-28 mm
- Product Dia. (Min-Max): 70-160 mm
- Product Height (Min-Max): 50-350mm
- Stretching Stroke (Min-Max): 150-350 mm
- Operation Air Pressure: ~ 1 MPa
- Blowing Air Pressure: ~ 3 MPa
- Production Rate: ~ 3,000-4,000 Pieces/hr
- Power: ~ 50 kW (380V 3 Phase)
- Dimension (LxWxH): ~2.5m x 2m x 2m
- FOB Price: USD 20,000-35,000 (New)
- Gross Weight: ~ 3 ton

3. Compression Molding Machine



- No. of Mold Cavity: ~ 18
- Cap Dia. (Min-Max): 20-42mm
- Cap Height (Min-Max): 10-30mm
- Air Consumption: ~ 50 cfm @ 10 bar
- Additional Feature: Folding, Slitting
- Production Rate: 15,000-18,000 Pieces/hr
- Power: ~ 60 kW
- Dimension (LxWxH): ~ 4m x 1.5m x 2m
- FOB Price: USD 40,000-80,000
- Gross Weight: ~ 5 ton

4. Mixing Machine or Blending Machine



- Mixing Capacity: 100 kg/hr (250 l)
- Motor Power: ~ 2-4 HP
- Rotating Speed: ~ 90 rpm
- Power: 1 kW (400V 3 Phase)
- Dimension (LxWxH):~ 1m x0.8m x0.85m
- Optional Feature: Timing Device, Heater
- FOB Price: USD 500-1,500 (New)
- Gross Weight: 150-200 kg

Machineries Supplier:

- Bangladesh Hardware & Machinery Merchants' Association (BHMMA), 5, Bangabandu Avenue (3rd Floor), Dhaka. Tel: +8802-9569783. Mobile: +8801924-424085.
- South Asia Trading. Tel: +8802-9667302, +8802-9667301.
- China Bangla Engineers & Consultants Ltd. Mobile: +8801914-867929, +8801716-752370.
- Kulsum Enterprise. Mobile: +8801913-544816.
- National World Export & Import (Pvt.) Co. Ltd. Mobile: +8801684-949001.
- Osmonic BD Ltd. Tel: +8802-9571117, +8802-9563079.

Production Process Flow Chart:

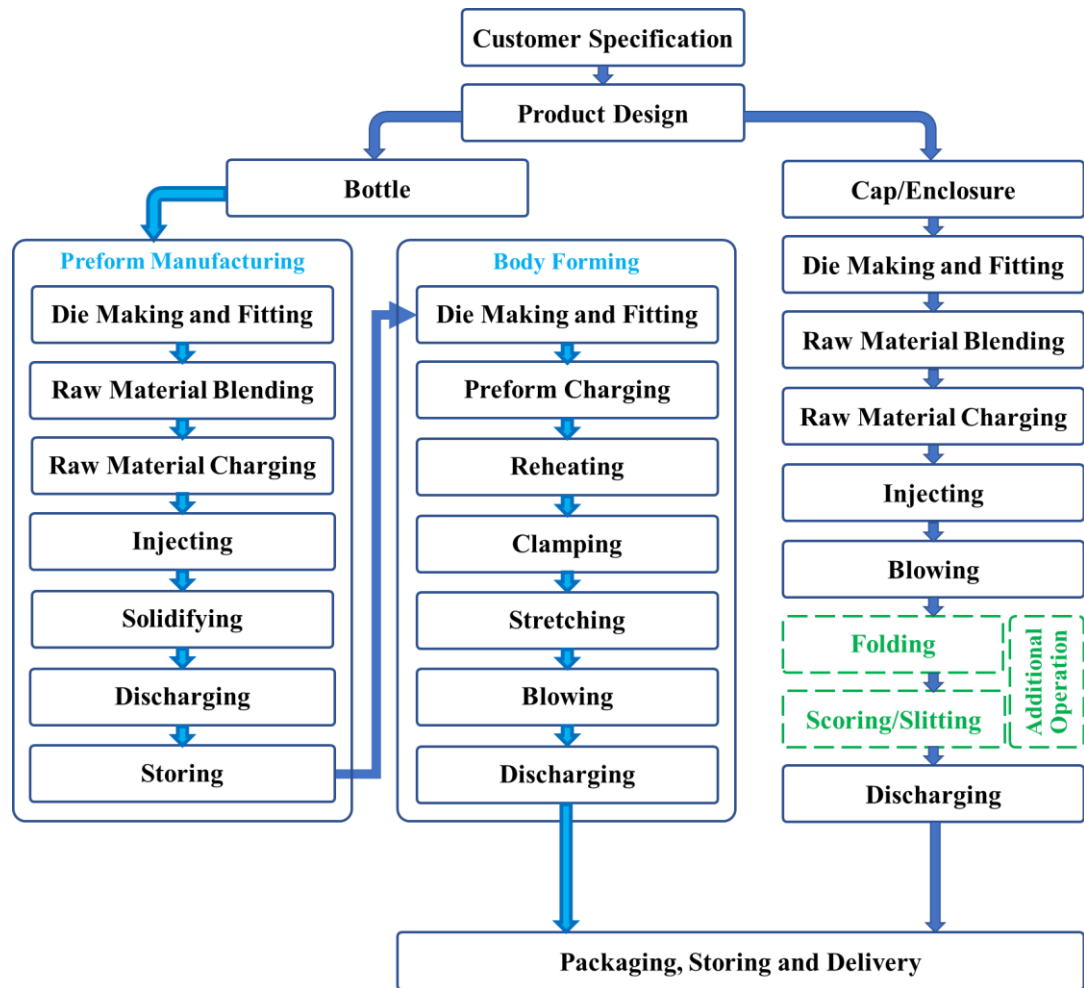

Die/Mold Supplier:

- Bangladesh Die & Mold Manufactures Association, 220, New Elephant Road, Dhaka. Tel: +8802-961545415. Mobile: +8801711-526913.

Bibliography:

- Rosato, Dominick V., Rosato, Andrew V., DiMattia, David P., “Blow Molding Handbook: Technology, Performance, Markets, Economics: The Complete Blow Molding Operation”, 2nd Rev. Edition, Hanser Publications, 2004.
- Brandau, Ottmar, “Stretch Blow Molding”, 3rd Edition, William Andrew, 2016.
- Belcher, Samuel L., “Practical Guide to Injection Blow Molding”, CRC Press, 2007.
- Davis, B., Gramann, P., Rios, A., Osswald, T., “Compression Molding”, Hanser Publications, 2003.

Product-02: Agricultural Sprayer

Sub-sector: Agricultural Product

HS-2007: 8424.81.10

BSIC-2009: 2821

BCPC-2011: 44150

Description:

A sprayer is a manually or mechanically operated device used to spray liquid such as herbicides, pesticides, insecticides, etc. It consists of container and delivery system with lever and nozzle.

Product:



Raw Materials:

Base Raw Material:

- High Density Polyethylene (HDPE)
- Low Density Polyethylene (LDPE)
- Polyethylene Terephthalate (PET)
- Polypropylene (PP)
- Polyvinyl Chloride (PVC)
- Styrene Acrylonitrile (SAN)

Additives:

- Process Aid and Mold Release
- Pigment

Raw Material Supplier:

- Bangladesh Polymer Importers' Association, 315/B, Tejgaon I/A, Dhaka. Tel: +8802-9830149.
- Bangladesh Chemical Importers and Merchants Association, 124, Hazaribagh, Dhaka-1209. Tel: +8802-8622608, +8802-8624009. Mobile: +8801986-842486.
- Bangladesh Paint Dyes & Chemical Merchants' Association, F.R.Plaza, 18, Imamganj, Dhaka-1100. Mobile: +8801755-651207, +8801711-938123, +8801819-074794.

Machineries and Specification:

1. Extrusion Blow Molding Machine



- No. of Station: 1; No. of Extrusion Layer: 1
- Product Size (LxWxD): ~600x400 x 200 mm
- Product Volume: Max. 25 L
- Production Rate: ~ 300-600 Pieces/hr
- Clamping Force: ~ 50 ton
- Mold Size: ~ 900 x 700 x 400 mm
- Blowing Pressure: ~ 3 MPa
- Power: ~ 100 kW (380V 3 Phase)
- Dimension (LxWxH): ~5 x 2.5 x 4 m
- FOB Price: USD 45,000-60,000
- Gross Weight: ~ 12 ton

2. Horizontal Injection Molding Machine



- Shot Size (Volume/Weight): ~ 450cc/650gm
- Injection Rate: ~180 gm/s
- Injection Pressure: ~160 MPa
- Clamping Force: ~220 ton
- Mold Size (HxW): 400 x 450 mm
- Mold Thickness (Min-Max): 150-450 mm
- Power: ~ 25 kW
- Dimension (LxWxH): ~5 x 1.5 x 2 m
- FOB Price: USD 45,000-60,000
- Gross Weight: ~ 5 ton

3. Mixing Machine or Blending Machine



- Mixing Capacity: 100 kg/hr (250 l)
- Motor Power: ~ 2-4 HP
- Rotating Speed: ~ 90 rpm
- Power: 1 kW (400V 3 Phase)
- Dimension (LxWxH): ~ 1 x 0.8 x 0.85 m
- Optional Feature: Timing Device, Heater
- FOB Price: USD 500-1,500
- Gross Weight: 150-200 kg

Machineries Supplier:

- Bangladesh Hardware & Machinery Merchants' Association (BHMMA), 5, Bangabandu Avenue (3rd Floor), Dhaka. Tel: +8802-9569783. Mobile: +8801924-424085.
- China Bangla Engineers & Consultants Ltd. Mobile: +8801914-867929, +8801716-752370.

Die/Mold Supplier:

- Bangladesh Die & Mold Manufactures Association, 220, New Elephant Road, Dhaka. Tel: +8802-961545415. Mobile: +8801711-526913.

Bibliography:

- Lee, Norman C., "Understanding Blow Molding", 2nd Edition, Hanser Gardner Publications, 2007.
- Belcher, Samuel L., "Practical Extrusion Blow Molding", UK Edition, Marcel Dekker, 2017.
- Kazmer, David O., "Blow Molding Design Guide", 2nd Edition, Hanser Gardner Publications, 2008.
- Rosato, Dominick V., Rosato, Andrew V., DiMattia, David P., "Blow Molding Handbook: Technology, Performance, Markets, Economics: The Complete Blow Molding Operation", 2nd Rev. Edition, Hanser Publications, 2004.

Production Process Flow Chart:

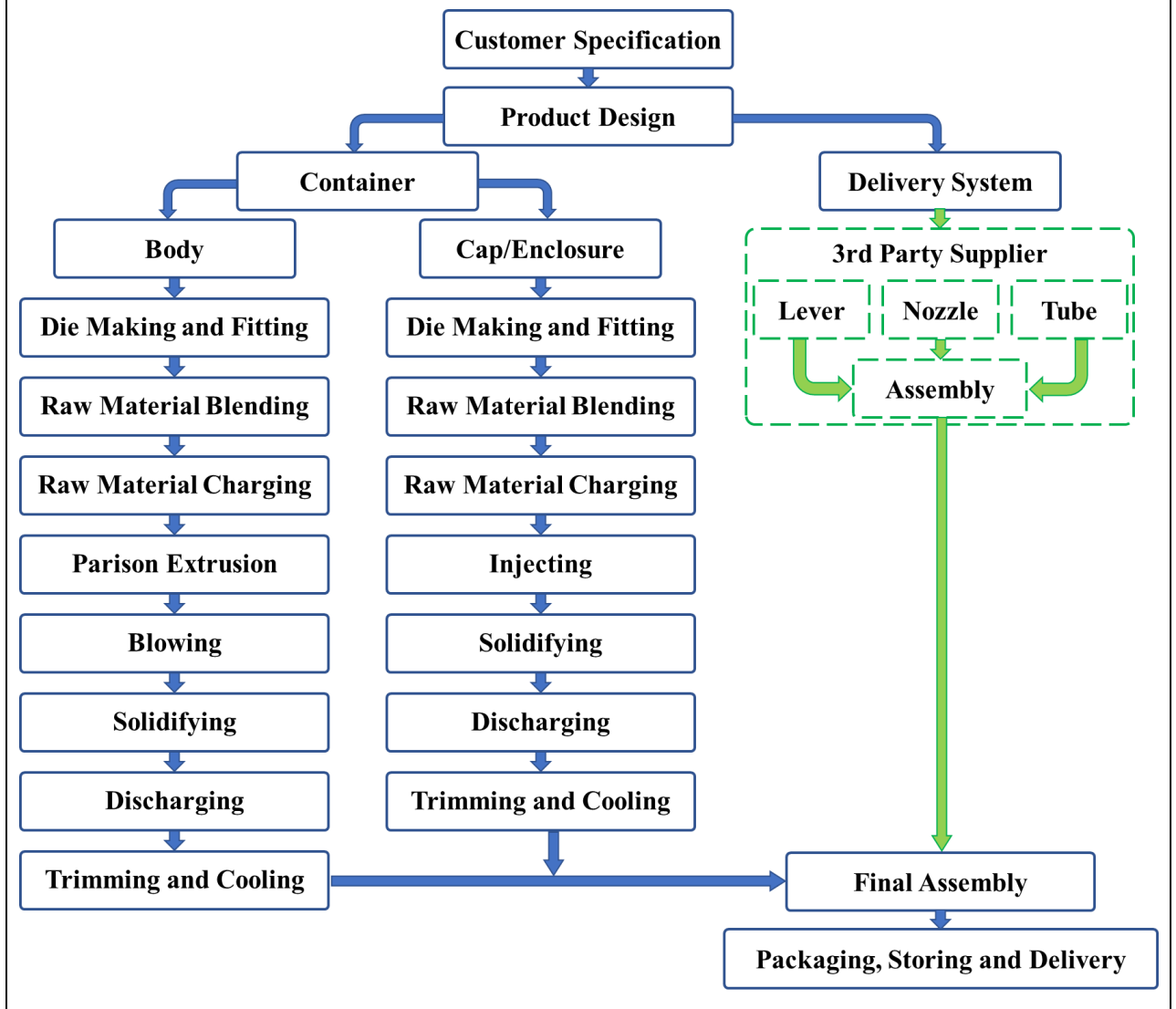

Product-03: Toolbox

Sub-sector: Packaging

HS-2007: 3923.10.00 **BSIC-2009:** 2220 **BCPC-2011:** 36490

Description:

A toolbox is a portable box to organize, hold and carry tools. Most portable toolboxes have one handle on top and a lid that opens on a hinge along with removable trays.

Product:



Raw Materials:

Base Raw Material: • High Density Polyethylene (HDPE) • Polypropylene (PP)

Additives: • Process Aid and Mold Release • Pigment

Raw Material Supplier:

- Bangladesh Polymer Importers' Association, 315/B, Tejgaon I/A, Dhaka. Tel: +8802-9830149.
- Bangladesh Chemical Importers and Merchants Association, 124, Hazaribagh, Dhaka-1209. Tel: +8802-8622608, +8802-8624009. Mobile: +8801986-842486.
- Bangladesh Paint Dyes & Chemical Merchants' Association, F.R.Plaza, 18, Imamganj, Dhaka-1100. Mobile: +8801755-651207, +8801711-938123, +8801819-074794.

Machineries and Specification:

1. Extrusion Blow Molding Machine



- No. of Station: 1; No. of Extrusion Layer: 1
- Product Size (LxWxD): ~600 x 400 x 200 mm
- Product Volume: Max. 25 L
- Production Rate: ~ 500-800 Pieces/hr
- Clamping Force: ~ 30 ton
- Mold Size: ~ 700 x 1200 x 400 mm
- Blowing Pressure: ~ 1.5 MPa
- Power: ~ 80 kW (380V 3 Phase)
- Dimension (LxWxH): ~4 x 2.5 x 3.5 m
- FOB Price: USD 45,000-60,000
- Gross Weight: ~ 10 ton

2. Horizontal Injection Molding Machine



- Shot Size (Volume/Weight): ~ 400cc/550gm
- Injection Rate: ~150 gm/s
- Injection Pressure: ~130 MPa
- Clamping Force: ~160 ton
- Mold Size (HxW): 400 x 450 mm
- Mold Thickness (Min-Max): 150-450 mm
- Power: ~ 25 kW (400V 3 Phase)
- Dimension (LxWxH): ~4 x 1.5 x 2 m
- FOB Price: USD 45,000-60,000
- Gross Weight: ~ 4 ton

3. Mixing Machine or Blending Machine



- Mixing Capacity: 100 kg/hr (250 l)
- Motor Power: ~ 2-4 HP
- Rotating Speed: ~ 90 rpm
- Power: 1 kW (400V 3 Phase)
- Dimension (LxWxH): ~ 1 x 0.8 x 0.85 m
- Optional Feature: Timing Device, Heater
- FOB Price: USD 500-1,500
- Gross Weight: 150-200 kg

Machineries Supplier:

- Bangladesh Hardware & Machinery Merchants' Association (BHMMA), 5, Bangabandu Avenue (3rd Floor), Dhaka. Tel: +8802-9569783. Mobile: +8801924-424085.
- South Asia Trading. Tel: +8802-9667302, +8802-9667301.
- China Bangla Engineers & Consultants Ltd. Mobile: +8801914-867929, +8801716-752370.
- National World Export & Import (Pvt.) Co. Ltd. Mobile: +8801684-949001.
- Osmonic BD Ltd. Tel: +8802-9571117, +8802-9563079.

Die/Mold Supplier:

- Bangladesh Die & Mold Manufactures Association, 220, New Elephant Road, Dhaka. Tel: +8802-961545415. Mobile: +8801711-526913.

Bibliography:

- Rosato, Dominick V., Rosato, Andrew V., DiMattia, David P., "Blow Molding Handbook: Technology, Performance, Markets, Economics: The Complete Blow Molding Operation", 2nd Rev. Edition, Hanser Publications, 2004.
- Lee, Norman C., "Plastic Blow Molding Handbook", Springer, 1990.
- Lee, Norman C., "Understanding Blow Molding", 2nd Edition, Hanser Gardner Publications, 2007.
- Belcher, Samuel L., "Practical Extrusion Blow Molding", UK Edition, Marcel Dekker, 2017.
- Kazmer, David O., "Blow Molding Design Guide", 2nd Edition, Hanser Gardner Publications, 2008.

Production Process Flow Chart:

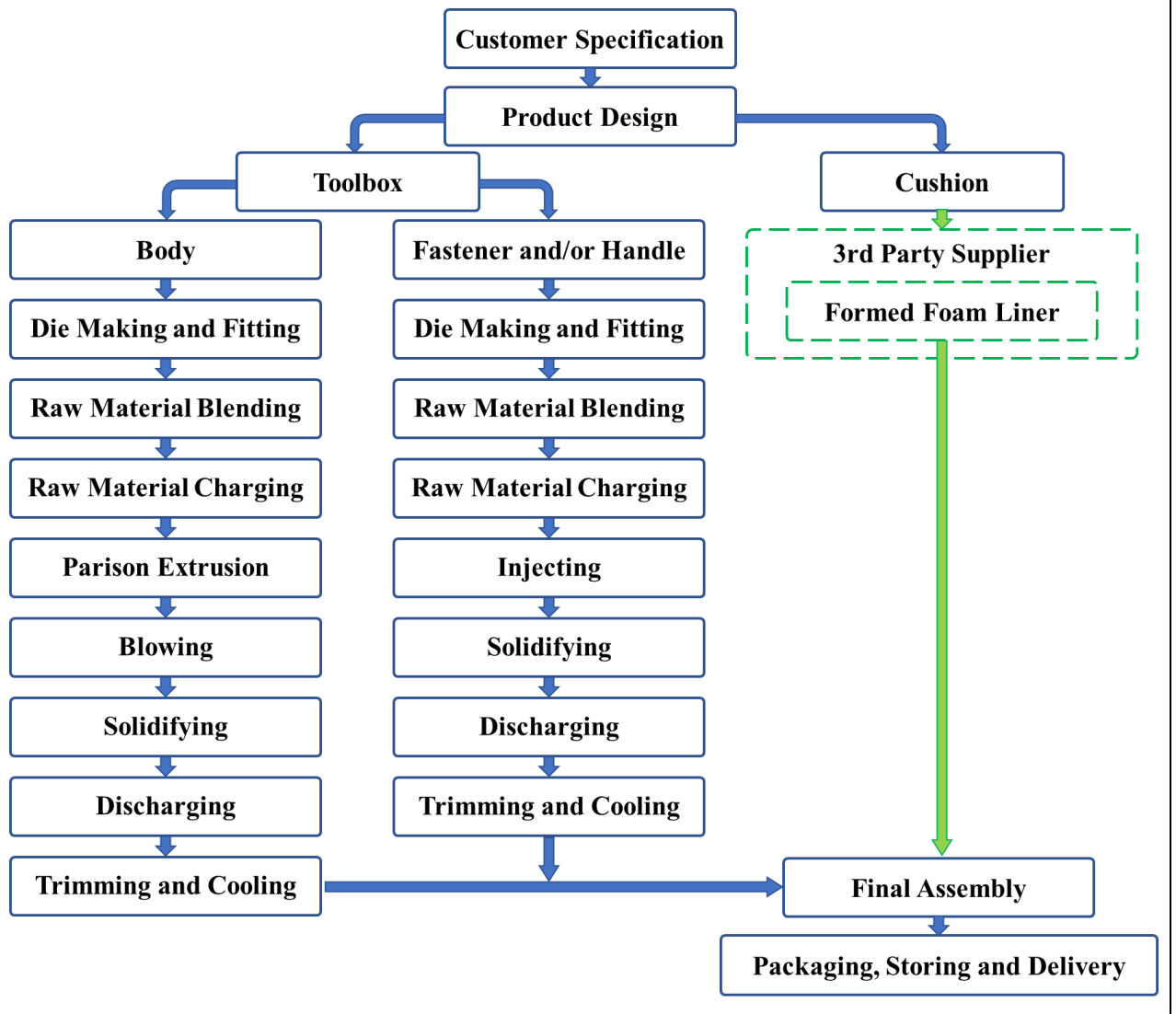

Product-04: Tricycle

Sub-sector:	Household, Tableware & Kitchenware				
HS-2007:	9503.00.90	BSIC-2009:	3240	BCPC-2011:	38510

Description:
A tricycle is a human-powered three-wheeled vehicle primarily used for recreational purposes for children.



Raw Materials:

Base Raw Material:	<ul style="list-style-type: none"> Acrylonitrile Butadiene Styrene (ABS) Polypropylene (PP)
Additives:	<ul style="list-style-type: none"> Process Aid and Mold Release Pigment

Raw Material Supplier:

- Bangladesh Polymer Importers' Association, 315/B, Tejgaon I/A, Dhaka. Tel: +8802-9830149.
- Bangladesh Chemical Importers and Merchants Association, 124, Hazaribagh, Dhaka-1209. Tel: +8802-8622608, +8802-8624009. Mobile: +8801986-842486.
- Bangladesh Paint Dyes & Chemical Merchants' Association, F.R.Plaza, 18, Imamganj, Dhaka-1100. Mobile: +8801755-651207, +8801711-938123, +8801819-074794.

Machineries and Specification:

1. Extrusion Blow Molding Machine

	<ul style="list-style-type: none"> No. of Station: 1; No. of Extrusion Layer: 1 Product Size (LxWxD): ~500x400x200 mm Product Volume: Max. 20 L Production Rate: ~ 150-200 Pieces/hr Clamping Force: ~ 50 ton Mold Size: ~ 800 x 600 x 400 mm Blowing Pressure: ~ 3 MPa Power: ~ 80 kW (380V 3 Phase) Dimension (LxWxH): ~4.5 x 2.5 x 3.5 m FOB Price: USD 35,000-50,000 Gross Weight: ~ 10 ton
---	--

2. Mixing Machine or Blending Machine



- Mixing Capacity: 100 kg/hr (250 l)
- Motor Power: ~ 2-4 HP
- Rotating Speed: ~ 90 rpm
- Voltage: 380V 3 Phase
- Dimension (LxWxH): ~ 1 x 0.8 x 0.85 m
- FOB Price: USD 500-1,500
- Gross Weight: 150-200 kg

Machineries Supplier:

- Bangladesh Hardware & Machinery Merchants' Association (BHMMA), 5, Bangabandu Avenue (3rd Floor), Dhaka. Tel: +8802-9569783. Mobile: +8801924-424085.
- China Bangla Engineers & Consultants Ltd. Mobile: +8801914-867929, +8801716-752370.

Production Process Flow Chart:

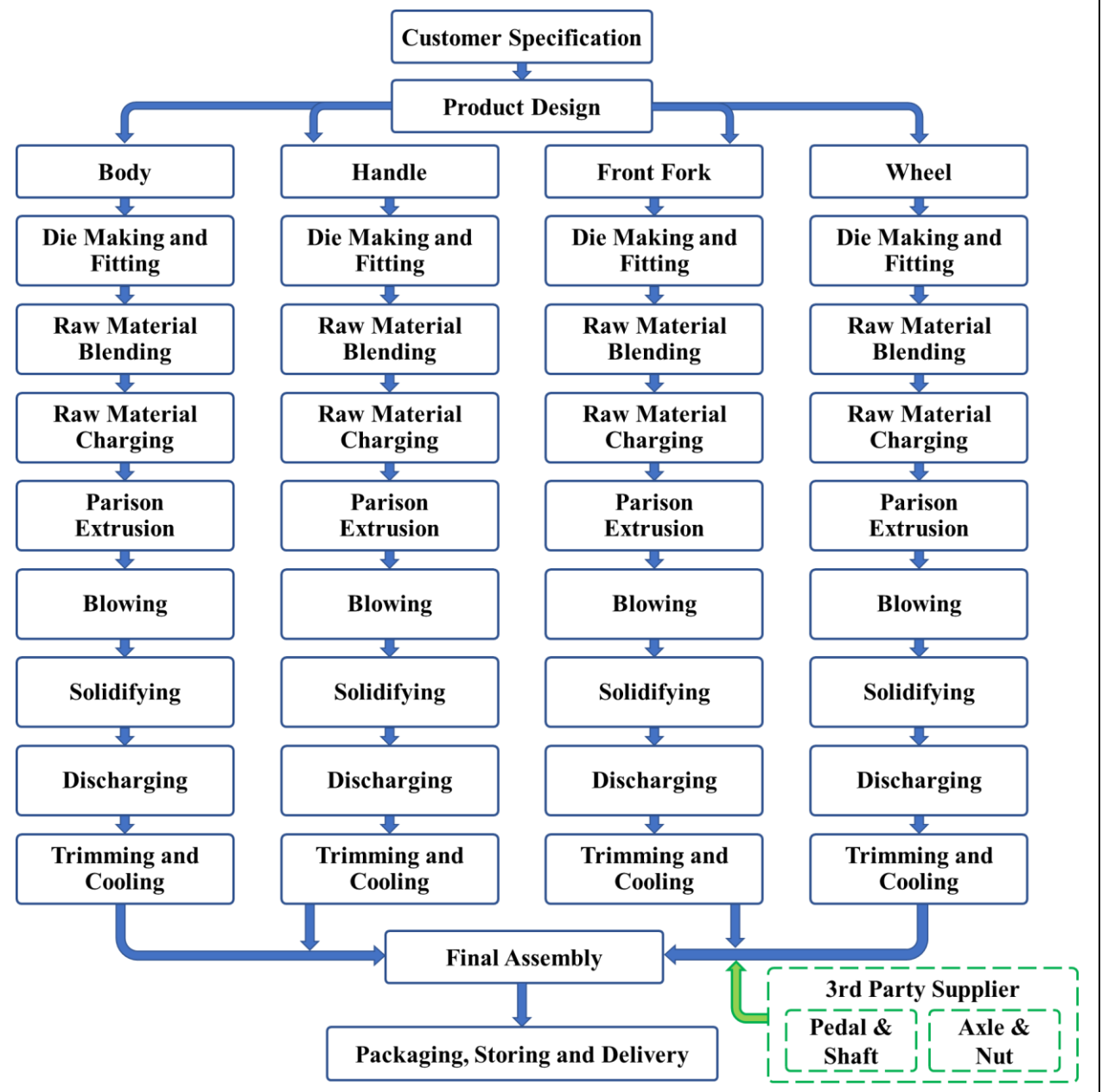

Die/Mold Supplier:

- Bangladesh Die & Mold Manufactures Association, 220, New Elephant Road, Dhaka.
Tel: +8802-961545415. Mobile: +8801711-526913.

Bibliography:

- Rosato, Dominick V., Rosato, Andrew V., DiMattia, David P., “Blow Molding Handbook: Technology, Performance, Markets, Economics: The Complete Blow Molding Operation”, 2nd Rev. Edition, Hanser Publications, 2004.
- Lee, Norman C., “Plastic Blow Molding Handbook”, Springer, 1990.
- Brandau, Ottmar, “Stretch Blow Molding”, 3rd Edition, William Andrew, 2016.
- Lee, Norman C., “Understanding Blow Molding”, 2nd Edition, Hanser Gardner Publications, 2007.
- Belcher, Samuel L., “Practical Extrusion Blow Molding”, UK Edition, Marcel Dekker, 2017.
- Belcher, Samuel L., “Practical Guide to Injection Blow Molding”, CRC Press, 2007.
- Kazmer, David O., “Blow Molding Design Guide”, 2nd Edition, Hanser Gardner Publications, 2008.

Chapter 3: Extrusion

Extrusion Process

Introduction:

Extrusion is a method of forming in which metals or plastics are forced through a die or series of dies, resulting in a specific shape of constant cross section. Plastics extrusion is a continuous process in which thermoplastic feedstock is converted to a molten, viscous fluid and then extruded into various shapes such as bar, rod, tube, and pipe. Plastic extrusion is also used to produce various profiles such as angles and channel shapes as well as mono-filaments and wiring insulation.

The two principal plastic extrusion processes are:

- Profile extrusion
- Blown film extrusion

Profile / sheet extrusion is a horizontal process and blown film extrusion is a vertical process.

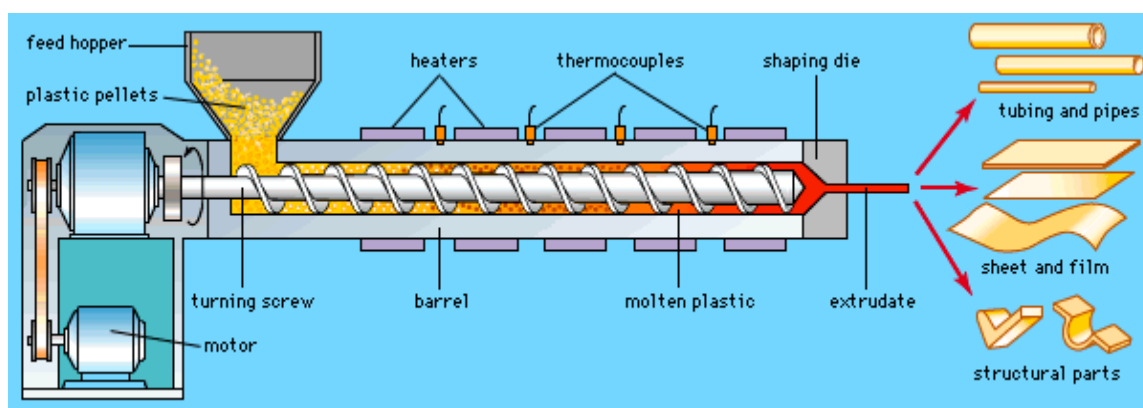

Fig. 5: Schematic representation of extrusion molding

Typical characteristics of extrusion:

- Scope of manufacturing hollow or solid shapes of different cross-section
- Possibility of producing one-piece part with no weld lines or joints
- Multilayer extrusion is achievable
- Minimal material wastage.

Possible defects and methods of elimination:

Sl.	Defect	Cause	Solution
1	Resin Defects	<ul style="list-style-type: none"> • Occlusions, char particles, voids • Filler/pigment not well distributed • Improper mixing of resin and additives • Foreign contamination 	<ul style="list-style-type: none"> • Screening the resin material • Exact addition of (Percentage of mixing) resin material

2	Surging	<ul style="list-style-type: none"> • Irregular take-off pulls • Uneven feed 	<ul style="list-style-type: none"> • Run extruder slower or faster • Replace the screw • Clean mold periodically
3	Part discoloration	<ul style="list-style-type: none"> • Contamination by foreign element • Inadequate environment 	<ul style="list-style-type: none"> • Decrease oven and/or heating cycle temperature • Purge the part with inert gas (N₂) • Use a resin with a suitable type and amount of antioxidant additive
4	Rough edges	<ul style="list-style-type: none"> • Improper mold closing 	<ul style="list-style-type: none"> • Provide a suitable amount of ventilation • Adjust periodically mold closing pressure • Clean mold edges to prevent leakage and/or accumulation
5	Poor strength	<ul style="list-style-type: none"> • Incomplete powder fusion 	<ul style="list-style-type: none"> • Increase oven and/or heating cycle temperature • Use a finer powder resin • Increase mold heat transfer

References:

- Birley, Arthur W., Batchelor, Jim, Haworth, Barry, “Physics of Plastics: Processing, Properties and Materials Engineering”, Oxford University Press, 1992.
- Levy, Sidney, “Plastics Extrusion Technology Handbook”, 2nd Rev. Edition, Industrial Press Inc., 1989.
- Noriega E., Maria Del Pilar, Rauwendaal, Chris, “Troubleshooting the Extrusion Process: A Systematic Approach to Solving Plastic Extrusion Problems”, 2nd Adapted Edition, Hanser Gardner Publications, 2010.
- Griff, Allan L., “Plastics Extrusion Technology”, Krieger Publication Co., 1976.
- Hensen, Friedhelm, “Plastics Extrusion Technology”, 2nd Edition, Hanser Gardner Publications, 1997.
- Brydson, J. A., “Principles of Plastics Extrusion”, Springer, 1973.
- Rauwendaal, Chris, “Polymer Extrusion”, 5th Rev. Edition, Hanser Gardner Publications, 2013.
- Michaeli, Walter, “Extrusion Dies for Plastics and Rubber Design and Engineering Computations”, 3rd Rev. Edition, Hanser Gardner Publications, 2003.
- Chung, Chan I., “Extrusion of Polymers: Theory and Practice”, 2nd Rev. Edition, Carl Hanser Verlag GmbH & Co., 2011.
- Cantor, Kirk, “Blown Film Extrusion”, 2nd Rev. Edition, Carl Hanser Verlag GmbH & Co., 2011.
- Richardson, Paul N., “Introduction to Extrusion”, Society of Plastics Engineers, 1974.
- Butler, Thomas I., “Film Extrusion Manual: Process, Materials, Properties”, 2nd Edition, Tappi, 2005.

Extrusion Products

Product-01: Pipe

Sub-sector: Building and Construction

HS-2007: 3917.22.00

BSIC-2009: 2220

BCPC-2011: 36320

Description:

A Pipe is a hollow cylinder usually with circular cross-section used mainly to convey substances which can flow—liquids and gases (fluids), slurries, powders and masses of small solids.

Product:



Raw Materials:

Base Raw Material: • Polyvinyl Chloride (PVC, uPVC, cPVC) • Polypropylene (PP)

Additives: • Process Aid and Mold Release • Pigment

Raw Material Supplier:

- Bangladesh Polymer Importers' Association, 315/B, Tejgaon I/A, Dhaka.
Tel: +8802-9830149.
- Bangladesh Chemical Importers and Merchants Association, 124, Hazaribagh, Dhaka-1209.
Tel: +8802-8622608, +8802-8624009. Mobile: +8801986-842486.
- Bangladesh Paint Dyes & Chemical Merchants' Association, F.R.Plaza, 18, Imamganj, Dhaka-1100. Mobile: +8801755-651207, +8801711-938123, +8801819-074794.

Machineries and Specification:

1. Twin Screw Extruder Machine



- Product Dia.: ~30 - 400 mm
- Plasticizing Capacity: Max. 170 kg/hr
- Output: Max. 150 kg/hr
- Thrust Bearing Dynamic Load: ~ 75 ton
- Screw Dia.: 90 mm
- Screw L/D Ratio: 20-40
- Power: ~ 80 kW (400V 3 Phase)
- Dimension (LxWxH): ~ 4 x 2 x 2.5 m
- Optional Feature: Dryer, Feeder
- FOB Price: USD 40,000-60,000
- Gross Weight: ~ 4 ton

2. Calibration Trough / Tank



- Pipe Dia.: ~ 30 – 400 mm
- Tank Length: ~ 4 – 6 m
- Number of Vacuum Chamber: 1
- Movement: Axial and Traverse (Slide rail)
- Power: ~ 8 kW (400V 3 Phase)
- Dimension (LxWxH): ~ 6 x 1 x 1.2 m
- FOB Price: USD 10,000-15,000
- Gross Weight: ~ 1.5 ton

3. Cooling Trough / Tank



- Pipe Dia.: ~ 30 – 400 mm
- Tank Length: ~ 4 – 6 m
- Movement: Axial and Traverse (Slide rail)
- Water Consumption: ~ 1.5 m³/hr
- Power: ~ 4 kW (400V 3 Phase)
- Dimension (LxWxH): ~ 6 x 1 x 1.2 m
- FOB Price: USD 8,000-10,000
- Gross Weight: ~ 1.2 ton

4. Haul Off/ Take Off/ Traction Unit



- Pipe Dia.: ~ 30 – 400 mm
- Pulling Speed: ~ 0.25 – 25 m/min
- Number of Traction Track: ~ 2 – 8
- Track Contact Length: ~ 50 – 1,500 mm
- Movement: Axial and Traverse (Slide rail)
- Optional Feature: Track Adjustment, Pressure Balance, etc.
- Power: ~ 5 kW (400V 3 Phase)
- Dimension (LxWxH): ~ 2.5 x 1 x 2 m
- FOB Price: USD 8,000-12,000
- Gross Weight: ~ 1.5 ton

5. Cutting Unit

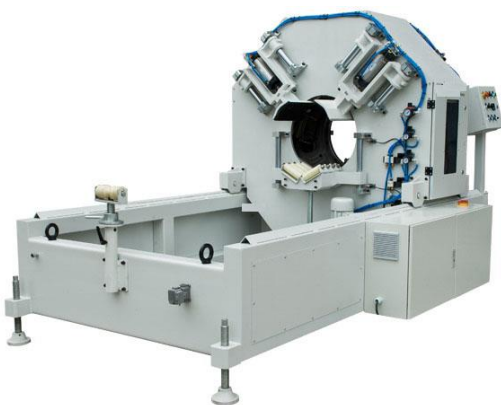

- Pipe Dia.: ~ 30 – 400 mm
- Cut-off Length: ~ 500 – 800 mm
- Cutter Type: Planetary (Carbide Tip)
- Cutting Speed: ~ 5 – 10 m/hr
- Clamping System: Universal / Top
- Optional Feature: Swarf Removal, Metering, Chamfering, Chipless Cutting, etc.
- Power: ~ 5 kW (400V 3 Phase)
- Dimension (LxWxH): ~ 2.5 x 1.5 x 2 m
- FOB Price: USD 10,000-15,000
- Gross Weight: ~ 2 ton

6. Belling Machine / Socketing Machine



- Pipe Dia.: ~ 30 – 400 mm
- Pipe Length: ~ 4 – 8 m
- Socketing Output: ~ 150 – 450 kg/hr
- Socketing Method: Pressure and Vacuum
- Working Pressure: ~ 4 – 6 MPa
- Number of Oven; 1
- Power: ~ 25 kW (400V 3 Phase)
- Dimension (LxWxH): ~ 7 x 3 x 2.5 m
- FOB Price: USD 20,000-35,000
- Gross Weight: ~ 4.5 ton

7. Mixing Machine



- Mixing Capacity: 100 kg/hr (250 l)
- Motor Power: ~ 2-4 HP
- Rotating Speed: ~ 90 rpm
- Power: ~ 3 kW (400V 3 Phase)
- Dimension (LxWxH): ~ 1 x 0.8 x 0.85 m
- Optional Feature: Timing Device, Heater
- FOB Price: USD 500-1,500
- Gross Weight: 150-200 kg

Machineries Supplier:

- Bangladesh Hardware & Machinery Merchants' Association (BHMMA), 5, Bangabandu Avenue (3rd Floor), Dhaka. Tel: +8802-9569783. Mobile: +8801924-424085.
- China Bangla Engineers & Consultants Ltd. Mobile: +8801914-867929, +8801716-752370.
- National World Export & Import (Pvt.) Co. Ltd. Mobile: +8801684-949001.
- South Asia Trading. Tel: +8802-9667302, +8802-9667301.
- Osmonic BD Ltd. Tel: +8802-9571117, +8802-9563079.

Die/Mold Supplier:

- Bangladesh Die & Mold Manufactures Association, 220, New Elephant Road, Dhaka. Tel: +8802-961545415. Mobile: +8801711-526913.

Bibliography:

- Levy, Sidney, "Plastics Extrusion Technology Handbook", 2nd Rev. Edition, Industrial Press Inc., 1989.
- Rauwendaal, Chris, "Polymer Extrusion", 5th Rev. Edition, Hanser Gardner Publications, 2013.
- Chung, Chan I., "Extrusion of Polymers: Theory and Practice", 2nd Rev. Edition, Carl Hanser Verlag GmbH & Co., 2011.

Production Process Flow Chart:

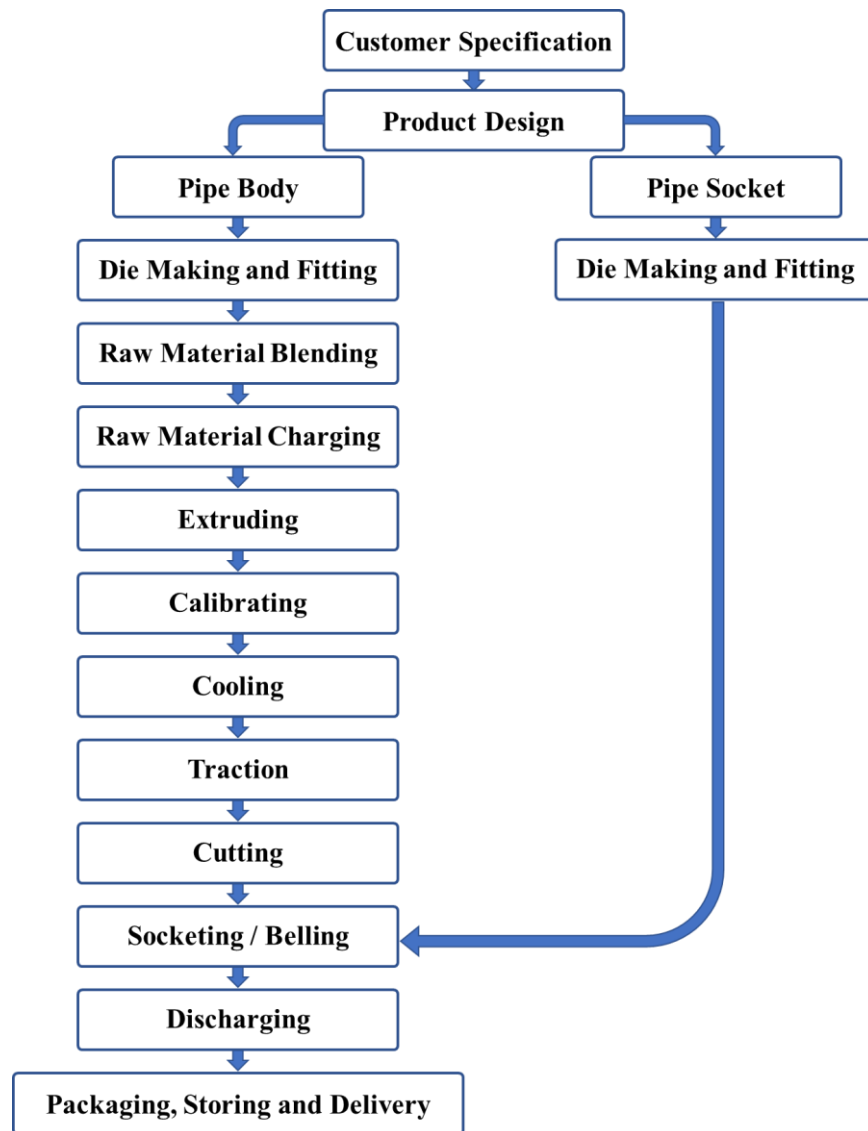

Product-02: Ballpoint Pen

Sub-sector: Household, Tableware & Kitchenware

HS-2007: 9608.10.10

BSIC-2009: 3290

BCPC-2011: 38911

Description:

A Ballpoint Pen is a writing instrument that dispenses ink via a metallic sphere at the pen's tip. There are two main types of ballpoint pens: disposable and refillable. Disposable pens contain a fixed plastic ink cartridge and are discarded when the ink is used up.

Product:



Raw Materials:

Base Raw Material: • High Density Polyethylene (HDPE) • Polypropylene (PP)

Additives: • Process Aid and Mold Release • Pigment

Raw Material Supplier:

- Bangladesh Polymer Importers' Association, 315/B, Tejgaon I/A, Dhaka. Tel: +8802-9830149.
- Bangladesh Chemical Importers and Merchants Association, 124, Hazaribagh, Dhaka-1209. Tel: +8802-8622608, +8802-8624009. Mobile: +8801986-842486.
- Bangladesh Paint Dyes & Chemical Merchants' Association, F.R.Plaza, 18, Imamganj, Dhaka-1100. Mobile: +8801755-651207, +8801711-938123, +8801819-074794.

Machineries and Specification:

1. Co-Extrusion Machine



- Product Dia.: ~5 - 15 mm
- Number of Layer: Min. 2
- Plasticizing Capacity: Max. 170 kg/hr
- Output: Max. 150 kg/hr
- Screw Dia.: 90 mm
- Screw L/D Ratio: 20-40
- Power: ~ 45 kW (400V 3 Phase)
- Dimension (LxWxH): ~ 3.5 x 3 x 2.5 m
- Optional Feature: Dryer, Feeder
- FOB Price: USD 50,000-70,000
- Gross Weight: ~ 6 ton

2. Calibration Trough / Tank

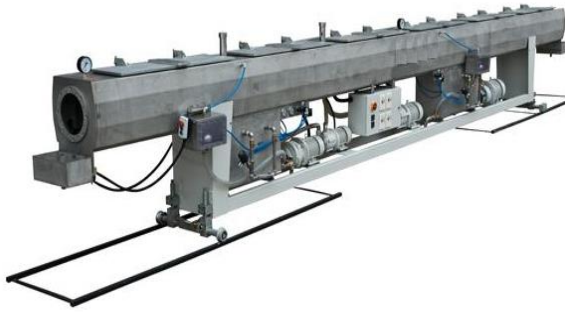

- Pen Dia.: ~ 5 – 60 mm
- Tank Length: ~ 3 – 5 m
- Calibration System: Roller Mandrel
- Movement: Axial (Slide rail)
- Power: ~ 5 kW (400V 3 Phase)
- Dimension (LxWxH): ~ 6 x 0.8 x 1.5 m
- FOB Price: USD 6,000-8,000
- Gross Weight: ~ 1.2 ton

3. Cooling Trough / Tank

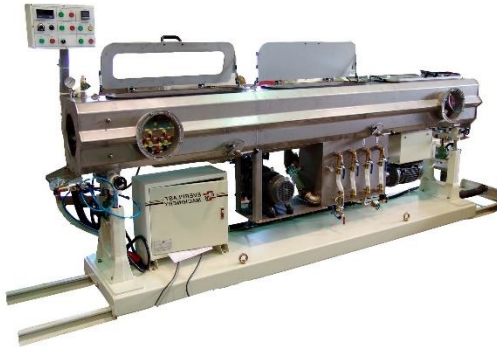

- Pen Dia.: ~ 5 – 60 mm
- Tank Length: ~ 3 – 5 m
- Movement: Axial (Slide rail)
- Water Consumption: ~ 1.5 m³/hr
- Power: ~ 5 kW (400V 3 Phase)
- Dimension (LxWxH): ~ 6 x 0.9 x 1.5 m
- FOB Price: USD 5,000-8,000
- Gross Weight: ~ 1.5 ton

4. Haul Off/ Traction and Cutting Machine



- Pen Dia.: ~ 5 – 60 mm
- Pulling Speed: ~ 0.5 – 15 m/min
- Number of Traction Track: 2
- Track Contact Length: ~ 50 – 100 mm
- Cutting Speed: ~ 5,000 cuts/min
- Cutter Type: Rotary
- Optional Feature: Track Adjustment, Pressure Balance, Metering, etc.
- Power: ~ 3 kW (400V 3 Phase)
- Dimension (LxWxH): ~ 1.5 x 0.8 x 2 m
- FOB Price: USD 6,000-8,000
- Gross Weight: ~ 0.8 ton

5. Chamfering Machine



- Pen Dia.: ~ 5 – 60 mm
- Cut-off Length: ~ 500 – 800 mm
- Cutter Type: Rotary
- Cutting Speed: ~ 5 – 10 m/hr
- Clamping System: Universal
- Optional Feature: Swarf Removal, Metering
- Power: ~ 2 kW (400V 3 Phase)
- Dimension (LxWxH): ~ 1.5 x 0.8 x 2 m
- FOB Price: USD 4,000-6,000
- Gross Weight: ~ 0.5 ton

6. Pen Assembly Machine



- Pen Dia.: ~ 5 – 60 mm
- Pen Length: ~ 200 mm
- Ink Tank Capacity: 10 l
- Production: ~ 300 – 1,000 pieces/hr
- Power: ~ 5 kW (400V 3 Phase)
- Dimension (LxWxH): ~ 7 x 3 x 2.5 m
- FOB Price: USD 20,000-35,000
- Gross Weight: ~ 4.5 ton

7. Centrifuge Machine



- Number of Station: ~ 4 – 8
- Holding Capacity: ~ 800 – 1,200 (5mm dia.)
- Rotation Speed: ~ 500 – 1,800 rpm
- Optional Feature: Timer, Rotation Counter
- Power: ~ 2 kW (400V 3 Phase)
- Dimension (LxWxH): ~ 1 x 0.8 x 0.8 m
- FOB Price: USD 3,000-5,000
- Gross Weight: ~ 0.3 ton

8. Mixing/ Blending Machine



- Mixing Capacity: 100 kg/hr (250 l)
- Motor Power: ~ 2-4 HP
- Rotating Speed: ~ 90 rpm
- Power: ~ 3 kW (400V 3 Phase)
- Dimension (LxWxH): ~ 1 x 0.8 x 0.85 m
- Optional Feature: Timing Device, Heater
- FOB Price: USD 500-1,500
- Gross Weight: 150-200 kg

Machineries Supplier:

- Bangladesh Hardware & Machinery Merchants' Association (BHMMA), 5, Bangabandu Avenue (3rd Floor), Dhaka. Tel: +8802-9569783. Mobile: +8801924-424085.
- China Bangla Engineers & Consultants Ltd. Mobile: +8801914-867929, +8801716-752370.

Die/Mold Supplier:

- Bangladesh Die & Mold Manufactures Association, 220, New Elephant Road, Dhaka. Tel: +8802-961545415. Mobile: +8801711-526913.

Bibliography:

- Levy, Sidney, "Plastics Extrusion Technology Handbook", 2nd Rev. Edition, Industrial Press Inc., 1989.
- Rauwendaal, Chris, "Polymer Extrusion", 5th Rev. Edition, Hanser Gardner Publications, 2013.
- Chung, Chan I., "Extrusion of Polymers: Theory and Practice", 2nd Rev. Edition, Carl Hanser Verlag GmbH & Co., 2011.

Production Process Flow Chart:

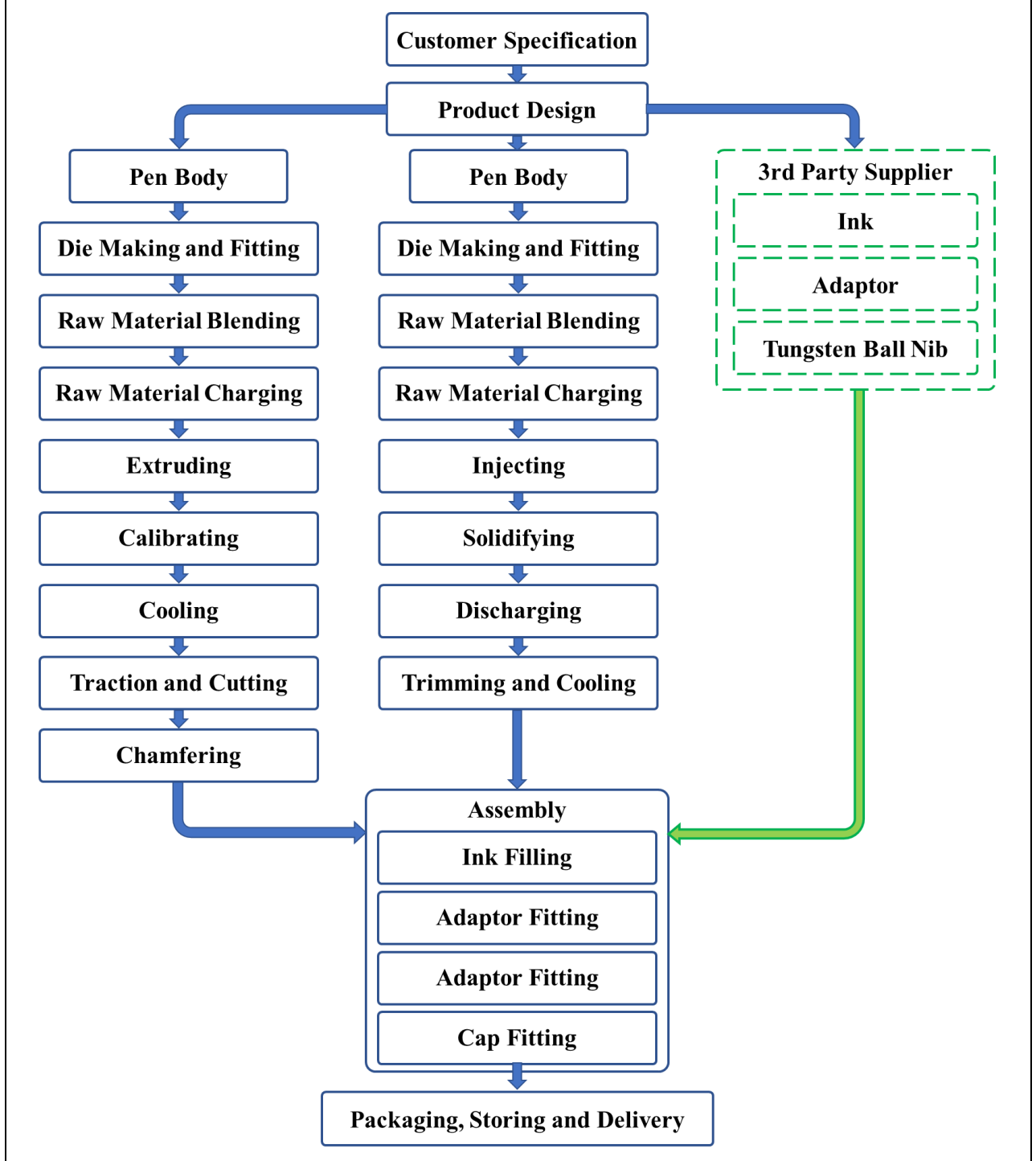

Product-03: Film or Sheet

Sub-sector: Packaging

HS-2007: 3920.10.90

BSIC-2009: 2220

BCPC-2011: 36330

Description:

Plastic Film or Sheet is a thin membrane-like continuous polymeric material typically used to separate areas or volumes, to hold items, to act as barriers, or as printable surfaces.

Product:



Raw Materials:

Base Raw Material: • Polypropylene (PP)

Additives: • Process Aid and Mold Release • Pigment

Raw Material Supplier:

- Bangladesh Polymer Importers' Association, 315/B, Tejgaon I/A, Dhaka.
Tel: +8802-9830149.
- Bangladesh Chemical Importers and Merchants Association, 124, Hazaribagh, Dhaka-1209.
Tel: +8802-8622608, +8802-8624009. Mobile: +8801986-842486.
- Bangladesh Paint Dyes & Chemical Merchants' Association, F.R.Plaza, 18, Imamganj, Dhaka-1100. Mobile: +8801755-651207, +8801711-938123, +8801819-074794.

Machineries and Specification:

1. Extrusion Machine



- Product Size (WxT): ~ 1,000 x 2 mm
- Production Rate: ~ 150-200 kg/hr
- Thrust Bearing Dynamic Load: ~ 30 ton
- Screw Dia.: 110 mm
- Screw L/D Ratio: 30-60
- Power: ~ 80 kW (400V 3 Phase)
- Dimension (LxWxH): ~ 4 x 2 x 3 m
- Optional Feature: Dryer, Feeder
- FOB Price: USD 40,000-60,000
- Gross Weight: ~ 4 ton

2. Polishing Stack and Haul Off Machine



- Sheet Thickness: ~ 0.25 – 20 mm
- Sheet Width: ~ 1 – 2 m
- Number of Polishing Roll: 3
- Polishing Roll Dia.: ~ 400 – 500 mm
- Speed: ~ 0.1 – 10 m/min
- Haul-off Traction: Double strand
- Power: ~ 30 kW (400V 3 Phase)
- Dimension (LxWxH): ~ 8 x 2.5 x 2.5 m
- FOB Price: USD 30,000-45,000
- Gross Weight: ~ 6 ton

3. Winding Machine



- Sheet Thickness: ~ 0.25 – 15 mm
- Sheet Width: ~ 1 – 2 m
- Number of Winding Roll: 2
- Speed: ~ 5 – 40 m/min
- Power: ~ 10 kW (400V 3 Phase)
- Dimension (LxWxH): ~ 7 x 3 x 2.5 m
- FOB Price: USD 6,000-8,000
- Gross Weight: ~ 2 ton

4. Slitting and Rewinding Machine



- Number of Station: 2
- Roll Dia.: ~ 1 – 1.5 m
- Roll Width: ~ 1 – 1.3 m
- Slitting Type: Rotary Knife
- Power: 50 kW (400V 3 Phase)
- Dimension (LxWxH): ~ 10 x 3.5 x 2.5 m
- FOB Price: USD 40,000 – 70,000
- Gross Weight: ~ 10 ton

5. Mixing Machine



- Mixing Capacity: 100 kg/hr (250 l)
- Motor Power: ~ 2-4 HP
- Rotating Speed: ~ 90 rpm
- Power: ~ 3 kW (400V 3 Phase)
- Dimension (LxWxH): ~ 1 x 0.8 x 0.85 m
- Optional Feature: Timing Device, Heater
- FOB Price: USD 500-1,500
- Gross Weight: 150-200 kg

Machineries Supplier:

- Bangladesh Hardware & Machinery Merchants' Association (BHMMA), 5, Bangabandu Avenue (3rd Floor), Dhaka. Tel: +8802-9569783. Mobile: +8801924-424085.

- China Bangla Engineers & Consultants Ltd. Mobile: +8801914-867929, +8801716-752370.
- National World Export & Import (Pvt.) Co. Ltd. Mobile: +8801684-949001.
- South Asia Trading. Tel: +8802-9667302, +8802-9667301.
- Osmonic BD Ltd. Tel: +8802-9571117, +8802-9563079.

Production Process Flow Chart:

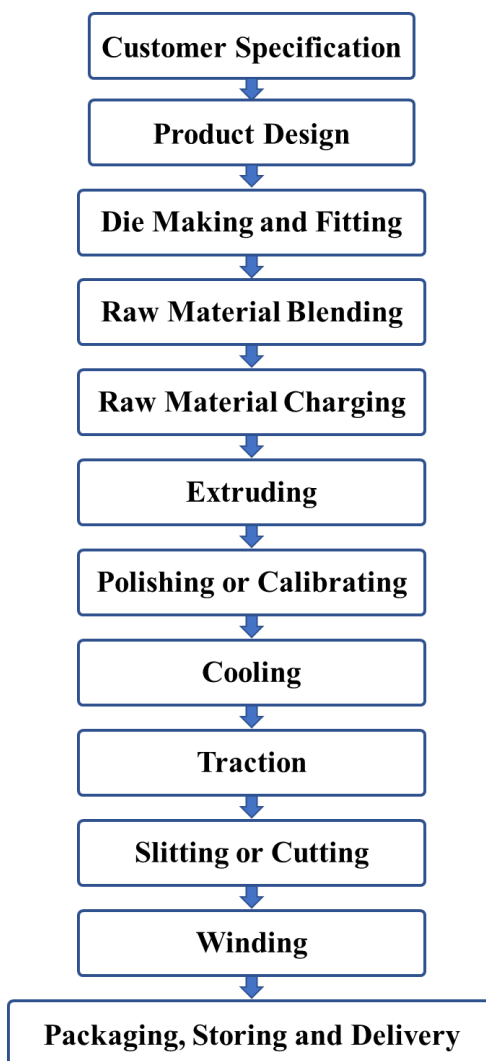

Die/Mold Supplier:

- Bangladesh Die & Mold Manufactures Association, 220, New Elephant Road, Dhaka.
Tel: +8802-961545415. Mobile: +8801711-526913.

Bibliography:

- Levy, Sidney, “Plastics Extrusion Technology Handbook”, 2nd Rev. Edition, Industrial Press Inc., 1989.
- Rauwendaal, Chris, “Polymer Extrusion”, 5th Rev. Edition, Hanser Gardner Publications, 2013.
- Chung, Chan I., “Extrusion of Polymers: Theory and Practice”, 2nd Rev. Edition, Carl Hanser Verlag GmbH & Co., 2011.

Product-04: Elastic Band

Sub-sector: RMG Accessories

HS-2007: 4016.99.90

BSIC-2009: 2219

BCPC-2011: 36270

Description:

An Elastic Band/ Rubber Band/ Lackey Band, is a short length of rubber and latex, elastic in nature and formed in the shape of thin circular rings which is commonly used to hold multiple objects together.

Product:



Raw Materials:

Base Raw Material: • Natural Rubber

Additives: • Process Aid and Mold Release • Pigment

Raw Material Supplier:





- Bangladesh Polymer Importers' Association, 315/B, Tejgaon I/A, Dhaka. Tel: +8802-9830149.
- Bangladesh Chemical Importers and Merchants Association, 124, Hazaribagh, Dhaka-1209. Tel: +8802-8622608, +8802-8624009. Mobile: +8801986-842486.
- Bangladesh Paint Dyes & Chemical Merchants' Association, F.R.Plaza, 18, Imamganj, Dhaka-1100. Mobile: +8801755-651207, +8801711-938123, +8801819-074794.

Machineries and Specification:

1. Extrusion Machine



- Product Dia.: ~ 40 - 200 mm
- Output: Max. 150 kg/hr
- Screw Dia.: 90 mm
- Screw L/D Ratio: 20-40
- Power: ~ 35 kW (400V 3 Phase)
- Dimension (LxWxH): ~ 4 x 2 x 3 m
- Optional Feature: Dryer, Feeder
- FOB Price: USD 15,000-25,000
- Gross Weight: ~ 4 ton

2. Cooling Trough / Tank	
	<ul style="list-style-type: none"> • Tube Dia.: ~ 40 – 400 mm • Tank Length: ~ 4 – 6 m • Movement: Axial and Traverse (Slide rail) • Water Consumption: ~ 2 m³/hr • Power: ~ 4 kW (400V 3 Phase) • Dimension (LxWxH): ~ 6 x 1 x 1.2 m • FOB Price: USD 8,000-10,000 • Gross Weight: ~ 1 ton
3. Haul Off/ Take Off/ Traction Machine	
	<ul style="list-style-type: none"> • Tube Dia.: ~ 30 – 400 mm • Pulling Speed: ~ 1 –20 m/min • Number of Traction Track: 2 • Track Contact Length: ~ 50 – 500 mm • Optional Feature: Track Adjustment, Pressure Balance, etc. • Power: ~ 3 kW (400V 3 Phase) • Dimension (LxWxH): ~ 2.5 x 0.9 x 2 m • FOB Price: USD 6,000-8,000 • Gross Weight: ~ 1 ton
4. Autoclave	
	<ul style="list-style-type: none"> • Effective Length: ~ 3 – 6 m • Effective Dia.: ~ 1 – 3 m • Heating Method: Electrical / Steam • Heating Medium: Pressure Air • Design Pressure: ~ 0.5 MPa • Power: ~ 15 kW (400V 3 Phase) • Dimension (LxWxH): ~ 7 x 3 x 3 m • FOB Price: USD 15,000-34,000 • Gross Weight: ~ 8 ton
5. Cutting/ Slicing Machine	
	<ul style="list-style-type: none"> • Cutting Width: ~ 0.1 – 100 mm • Cutting Length: ~ 1 – 9,999 mm • Cutting Type: Shear Knife • Cutting Material: High Speed Steel • Cutting Speed: ~ 150 pieces/min • Power: ~ 0.5 kW (220V) • Dimension (LxWxH): ~ 0.4 x 0.3 x 0.3 m • FOB Price: USD 1,500-2,500 • Gross Weight: ~ 0.05 ton

6. Banbury Mixing Machine



- Roll Working Dia.: ~ 250 mm
- Roll Working Length: ~ 600 mm
- Roll Surface Speed: ~ 15 m/min
- Friction Ratio: ~ 1: 1.2
- Max. Nip: ~ 8 mm
- Mixing Capacity: 150 kg/hr
- Power: ~ 15 kW (400V 3 Phase)
- Dimension (LxWxH): ~ 3.5 x 1.5 x 2 m
- FOB Price: USD 12,000-20,000
- Gross Weight: ~ 5 ton

Machineries Supplier:

- Bangladesh Hardware & Machinery Merchants' Association (BHMMA), 5, Bangabandu Avenue (3rd Floor), Dhaka. Tel: +8802-9569783. Mobile: +8801924-424085.
- China Bangla Engineers & Consultants Ltd. Mobile: +8801914-867929, +8801716-752370.
- National World Export & Import (Pvt.) Co. Ltd. Mobile: +8801684-949001.

Production Process Flow Chart:

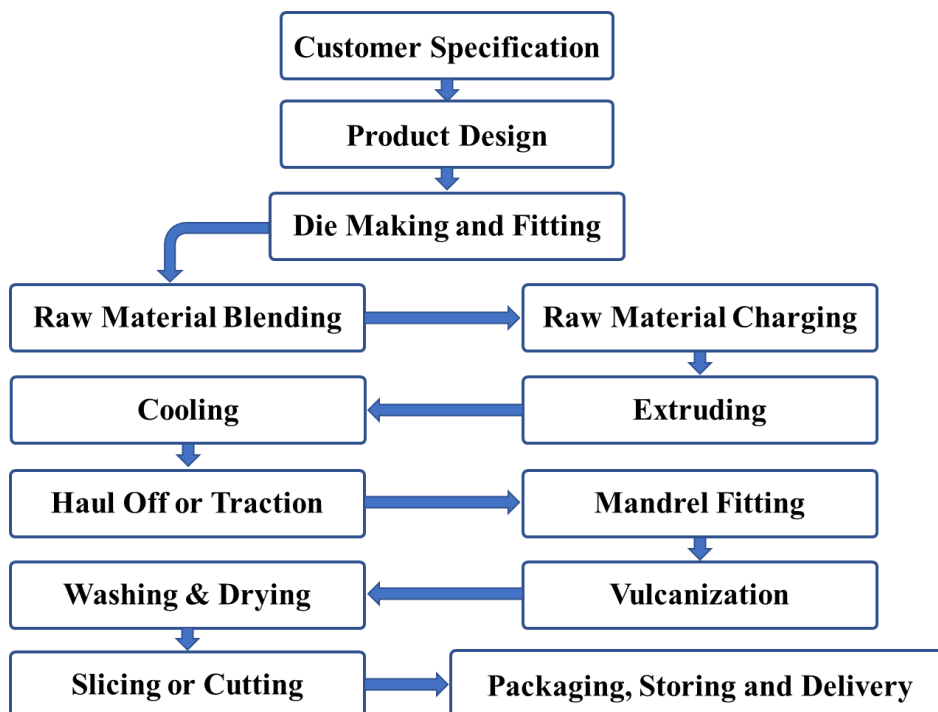

Die/Mold Supplier:

- Bangladesh Die & Mold Manufactures Association, 220, New Elephant Road, Dhaka. Tel: +8802-961545415. Mobile: +8801711-526913.

Bibliography:

- Birley, Arthur W., Batchelor, Jim, Haworth, Barry, "Physics of Plastics: Processing, Properties and Materials Engineering", Oxford University Press, 1992.
- Brydson, J. A., "Principles of Plastics Extrusion", Springer, 1973.

Product-05: Door Mat

Sub-sector: Household, Tableware & Kitchenware

HS-2007: 3918.10.00

BSIC-2009: 2220

BCPC-2011: 36910

Description:

A Door Mat is a flat rectangular object placed immediately outside or inside the entrance of a building to allow people to easily scrub or wipe the soles of shoes.

Product:



Raw Materials:

Base Raw Material:	<ul style="list-style-type: none"> • Polyamides (Nylon) • Polyvinyl Chloride (PVC)
Additives:	<ul style="list-style-type: none"> • Process Aid and Mold Release • Pigment

Raw Material Supplier:

- Bangladesh Polymer Importers' Association, 315/B, Tejgaon I/A, Dhaka. Tel: +8802-9830149.
- Bangladesh Chemical Importers and Merchants Association, 124, Hazaribagh, Dhaka-1209. Tel: +8802-8622608, +8802-8624009. Mobile: +8801986-842486.
- Bangladesh Paint Dyes & Chemical Merchants' Association, F.R.Plaza, 18, Imamganj, Dhaka-1100. Mobile: +8801755-651207, +8801711-938123, +8801819-074794.

Machineries and Specification:

1. Co-Extrusion Machine



- Sheet Size (WxT): ~ 1,000 x 200 mm
- Plasticizing Capacity: Max. 250 kg/hr
- Output: Max. 200 kg/hr
- Screw Dia.: 90 mm
- Screw L/D Ratio: 20-40
- Power: ~ 80 kW (400V 3 Phase)
- Dimension (LxWxH): ~ 3.5 x 3 x 2.5 m
- Optional Feature: Dryer, Feeder
- FOB Price: USD 40,000-60,000
- Gross Weight: ~ 8 ton

2. Extrusion Machine



- Product Size (WxT): ~ 1,000 x 5 mm
- Production Rate: ~ 150-200 kg/hr
- Thrust Bearing Dynamic Load: ~ 50 ton
- Screw Dia.: 110 mm
- Screw L/D Ratio: 32:1
- Power: ~ 55 kW (400V 3 Phase)
- Dimension (LxWxH): ~ 4 x 2 x 3 m
- Optional Feature: Dryer, Feeder
- FOB Price: USD 45,000-70,000
- Gross Weight: ~ 5 ton

3. Forming Roller Unit



- Sheet Thickness: ~ 10 – 200 mm
- Sheet Width: ~ 800 – 1,200 mm
- Number of Polishing Roll: 6
- Polishing Roll Dia.: ~ 400 – 500 mm
- Speed: ~ 0.1 – 10 m/min
- Power: ~ 25 kW (400V 3 Phase)
- Dimension (LxWxH): ~ 2.5 x 1.8 x 2.5 m
- FOB Price: USD 8,000-15,000
- Gross Weight: ~ 3 ton

4. Cooling Trough Unit



- Sheet Width: Max. 1,500 mm
- Tank Length: ~ 2 – 5 m
- Conveyor Roller: 4 nos.
- Tank Movement: Axial (Slide rail)
- Water Consumption: ~ 1.5 m³/hr
- Power: ~ 3 kW (400V 3 Phase)
- Dimension (LxWxH): ~ 3 x 1.5 x 1.2 m
- FOB Price: USD 2,500-5,000
- Gross Weight: ~ 1 ton

5. Haul-off Machine



- Sheet Thickness: ~ 30 – 400 mm
- Sheet Width: ~ Max. 1,500 mm
- Haul off Roll: 2 nos. (Rubber)
- Speed: ~ 1 – 10 m/min
- Optional Feature: Track Adjustment, Pressure Balance, etc.
- Power: ~ 5 kW (400V 3 Phase)
- Dimension (LxWxH): ~ 2 x 2.5 x 2.5 m
- FOB Price: USD 8,000-12,000
- Gross Weight: ~ 1 ton

6. Conveyor Drying Oven



- Conveyor Size (LxWxH): ~ 12 x 2 x 0.1 m
- Conveyor Type: Mesh/ Flat Wire Belt
- Conveyor Extension: 2 m (Entrance & Exit)
- Conveyor Speed: ~ 0.1 – 1 m/min
- Heat Source: Modulating Gas Burner (2 nos.)
- Operating Temperature: 100 – 300°C
- Insulation: 6 inches (Ceramic Fiber Blanket)
- Power: ~ 10 kW (400V 3 Phase)
- Dimension (LxWxH): ~ 15 x 3 x 3 m
- FOB Price: USD 12,000-25,000
- Gross Weight: ~ 7 ton

7. Hot Melt Coating and Laminating Machine



- Coating Width: ~ 500 – 1,500 mm
- Coating Deposition: ~ 10 – 200 g/m²
- Coating Speed: ~ 50 m/min
- Unwind Roll Dia.: Max. 1,000 mm
- Rewind Roll Dia.: Max. 800 mm
- Power: ~ 30 kW (400V 3 Phase)
- Dimension (LxWxH): ~ 5 x 2.5 x 2.5 m
- FOB Price: USD 10,000-20,000
- Gross Weight: ~ 6 ton

8. Conveyor Curing Oven



- Conveyor Size (LxWxH): ~ 9 x 1.5 x 0.1 m
- Conveyor Type: Mesh/ Flat Wire Belt
- Conveyor Extension: 2 m (Entrance & Exit)
- Conveyor Speed: ~ 0.1 – 1 m/min
- Heat Source: Modulating Gas Burner (2 nos.)
- Operating Temperature: 100 – 300°C
- Insulation: 6 inches (Ceramic Fiber Blanket)
- Power: ~ 10 kW (400V 3 Phase)
- Dimension (LxWxH): ~ 10 x 2.5 x 3 m
- FOB Price: USD 10,000-18,000
- Gross Weight: ~ 5 ton

9. CNC Cutting Machine



- Cutting Area (LxW): ~ 2.5 x 1.5 m
- Cutting Tool: Oscillating Knife
- Cutting Speed: Max. 1.5 m/sec
- Cutting Dia.: Min. 6 mm
- Cutting Thickness: Max. 30 mm
- Power: ~ 6 kW (400V 3 Phase)
- Dimension (LxWxH): ~ 3 x 2.5 x 1.3 m
- FOB Price: USD 10,000-25,000
- Gross Weight: ~ 2 ton

10. Printing Machine



- Print Area (LxW): ~ 2.5 x 1.5 m
- Material Thickness: Max. 100 mm
- Print Resolution: ~ 600 x 1,200 dpi
- Ink Color: CMYK
- Print Head: 3 – 8 nos.
- Printing Speed: ~ 15 sq. m/hr
- Power: ~ 5 kW (220V)
- Dimension (LxWxH): ~ 3.5 x 2 x 1.2 m
- FOB Price: USD 12,000-20,000
- Gross Weight: ~ 1.2 ton

11. High Speed Mixer



- Motor: 0.5 HP
- Rotation: Max. 1,200 rpm
- Container Capacity: Max. 20 kg
- Power: ~ 0.5 kW (220V)
- Dimension (LxWxH): ~ 0.5 x 0.6 x 1.2 m
- FOB Price: USD 500-1,000
- Gross Weight: 100-150 kg

Machineries Supplier:

- Bangladesh Hardware & Machinery Merchants' Association (BHMMA), 5, Bangabandu Avenue (3rd Floor), Dhaka. Tel: +8802-9569783. Mobile: +8801924-424085.
- China Bangla Engineers & Consultants Ltd. Mobile: +8801914-867929, +8801716-752370.

Die/Mold Supplier:

- Bangladesh Die & Mold Manufactures Association, 220, New Elephant Road, Dhaka. Tel: +8802-961545415. Mobile: +8801711-526913.

Bibliography:

- Rauwendaal, Chris, "Polymer Extrusion", 5th Rev. Edition, Hanser Gardner Publications, 2013.
- Chung, Chan I., "Extrusion of Polymers: Theory and Practice", 2nd Rev. Edition, Carl Hanser Verlag GmbH & Co., 2011.

Production Process Flow Chart:

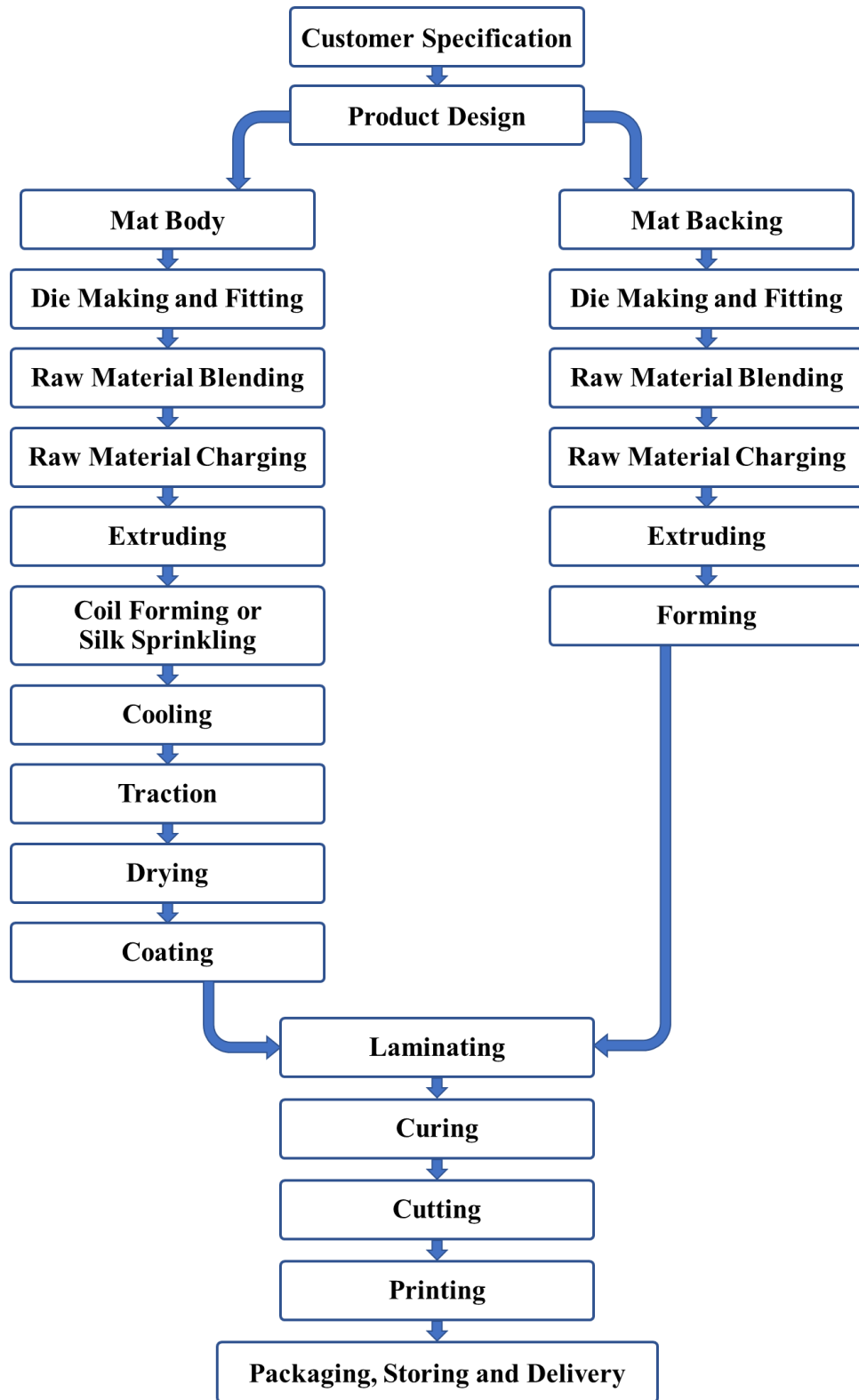

Chapter 4: Rotational Molding

Rotational Molding Process

Introduction:

Rotational molding, known also as rotomolding or rotocasting or slush molding, is a process for manufacturing hollow plastic products. In this process, plastic powders are added into a shell-like mold and the mold is then rotated about two axes while heating it and the powder. During rotation, the powder fuses against the inner mold surface into a bubble-free liquid layer. The polymer is then cooled to near room temperature, and the resulting hollow part is removed.

There are three types of rotational molding operations, i.e. i) rotary rotational molding, ii) shuttle rotational molding and iii) rack-n-roll rotational molding. Schematic representation of rotational molding is given below:

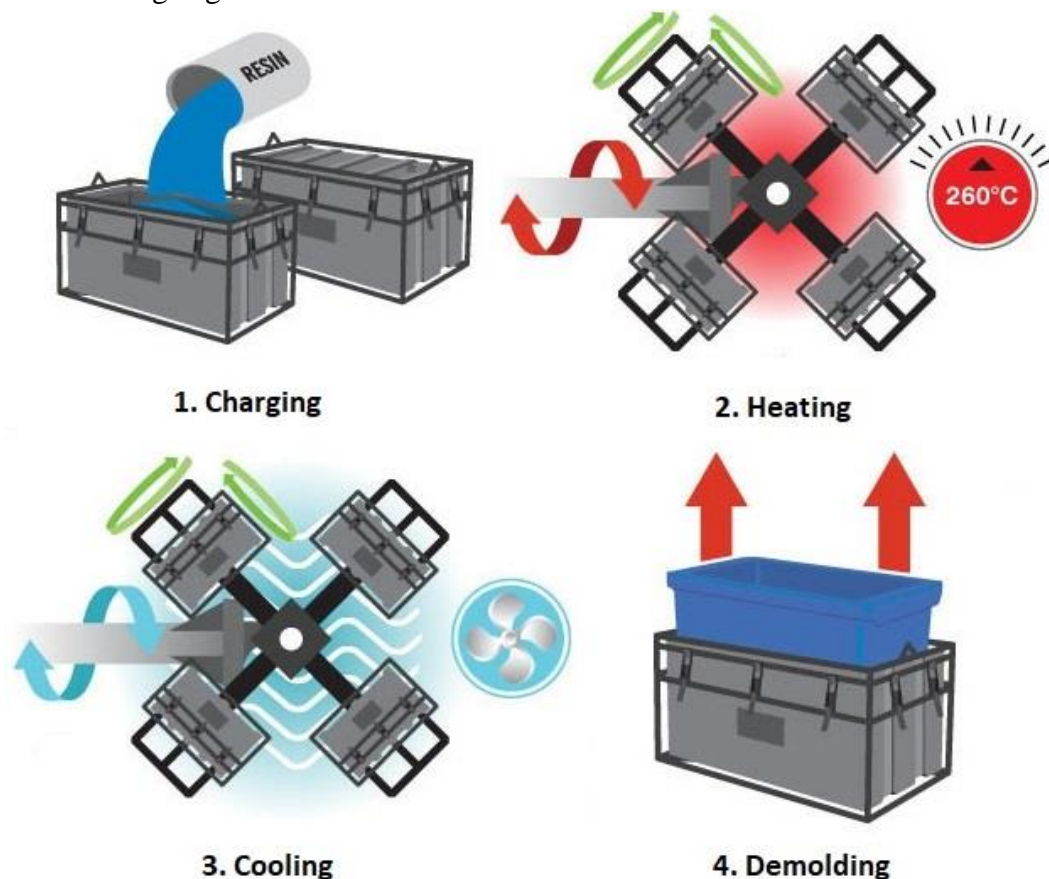

Fig. 6: Schematic representation of rotational molding

Typical characteristics of rotational molding:

- Most favorable process for producing stress-free parts
- Possibility of producing one-piece part with no weld lines or joints
- Molds are inexpensive and require short manufacturing lead-time
- Ideal for manufacturing large (>2m³) object
- Economically viable for short production runs
- Most minimal material wastage.

Possible defects and methods of elimination:

Sl.	Defect	Cause	Solution
1	Warpage	<ul style="list-style-type: none">• Non-uniform cooling	<ul style="list-style-type: none">• Decrease cooling speed• Increase cooling temperature• Maintain mold rotation during cooling• Provide suitable ventilation• Decrease the amount of the unmolding agent
2	Part Sticking	<ul style="list-style-type: none">• Improper unmolding agent• Improper mold cleaning	<ul style="list-style-type: none">• Select appropriate unmolding agent considering temperature and resin• Improve mold inner surface finish• Provide suitable ventilation• Clean mold periodically
3	Part discoloration	<ul style="list-style-type: none">• Contamination by foreign element• Inadequate environment	<ul style="list-style-type: none">• Decrease oven and/or heating cycle temperature• Purge the part with inert gas (N₂)• Use a resin with a suitable type and amount of antioxidant additive
4	Rough edges	<ul style="list-style-type: none">• Improper mold closing	<ul style="list-style-type: none">• Provide a suitable amount of ventilation• Adjust periodically mold closing pressure• Clean mold edges to prevent leakage and/or accumulation• Reduce, if used, mold inner air pressure
5	Poor strength	<ul style="list-style-type: none">• Incomplete powder fusion	<ul style="list-style-type: none">• Increase oven and/or heating cycle temperature• Use a finer powder resin• Increase mold heat transfer by manufacturing thinner mold walls or manufacture the mold with higher heat-transfer- rate material

References:

- Crawford, Roy J., Throne, James L., “Rotational Molding Technology”, William Andrew, 2003.
- Crawford, Roy J., Kearns, Mark P., “Practical Guide to Rotational Moulding”, Rapra Technology Limited, 2003.
- Beall, Glenn L., “Rotational Moulding: Design Materials Tooling and Processing”, Hanser Publications, 1998.

Rotational Molded Products

Product-01: Water Tank

Sub-sector:	Building and Construction				
HS-2007:	3925.10.00	BSIC-2009:	2220	BCPC-2011:	36950

Description:
 A water tank is a container for storing water to be used in drinking, farming, irrigation, fire suppression, commercial & industrial applications, etc. placed in desired location (overhead, ground, underground, mobile).



Raw Materials:	
Base Raw Material:	<ul style="list-style-type: none"> • High Density Polyethylene (HDPE) • Low Density Polyethylene (LDPE) • Linear Low Density Polyethylene (LLDPE)
Additives:	<ul style="list-style-type: none"> • Process Aid and Mold Release • Pigment

Raw Material Supplier:

- Bangladesh Polymer Importers' Association, 315/B, Tejgaon I/A, Dhaka. Tel: +8802-9830149.
- Bangladesh Chemical Importers and Merchants Association, 124, Hazaribagh, Dhaka-1209. Tel: +8802-8622608, +8802-8624009. Mobile: +8801986-842486.
- Bangladesh Paint Dyes & Chemical Merchants' Association, F.R.Plaza, 18, Imamganj, Dhaka-1100. Mobile: +8801755-651207, +8801711-938123, +8801819-074794.

Machineries and Specification:

1. Carousel Type Rotational Molding Machine

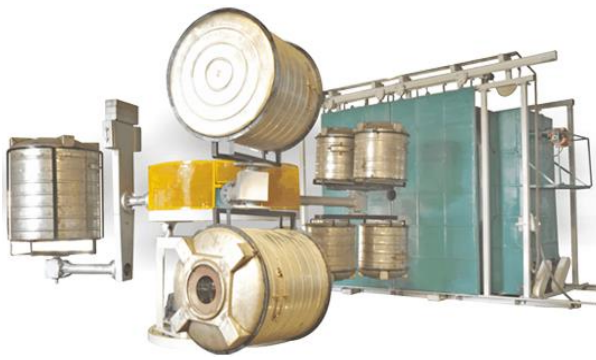
	<ul style="list-style-type: none"> • No. of Arm: 3; Arm Type: Straight/ Offset/ C • Product Size (HxD): ~1200 x 1100 mm • Product Volume: Max. 1200 L • Mold Load Capacity: Max. 200 kg • Heater Type: Burner (Gas/ Diesel) • Oven Size (LxWxH): 3.5 x 2.5 x 3.5 m • Power: ~ 20 kW (380V 3 Phase) • Dimension (LxWxH): ~ 10 x 12 x 3.5 m • FOB Price: USD 30,000-60,000 • Gross Weight: ~ 10 ton
---	---

2. High Speed Mixer Machine



- Useful Volume: ~ 350 Liter
- Mixing Capacity: ~ 180 kg/hr
- Motor Power: ~ 90 HP
- Speed: ~ 2 Variable Speed
- Power: 80 kW (380V 3 Phase)
- Dimension (LxWxH): ~ 2.5 x 1.5 x 2.5 m
- Optional Feature: Timer, Heater, PLC
- FOB Price: USD 3,000-8,000
- Gross Weight: ~ 2 ton

3. Pellet Extruder Machine



- Screw Dia.: ~50 mm
- Screw Length: ~ 210 mm
- Screw L/D: 30-60
- Power: ~ 55 kW
- Production Capacity: ~ 200-250 kg/hr
- Dimension (LxWxH): ~ 4 x 2.5 x 2 m
- Optional Feature: Dryer, Feeder
- FOB Price: USD 20,000-35,000
- Gross Weight: ~ 3.5 ton

4. Pulverizing / Micronizing Machine



- No. of Mills: 1
- Grinding Media: Disk (2 double faced taper)
- Sifter Type: Centrifugal
- Total Sifter Area (4 decks): ~ 2,500 sq. in.
- Production Rate (30 Mesh): ~ 650 kg/hr
- Power: ~ 65 kW
- Dimension (LxWxH): ~ 2.5 x 2 x 5 m
- Optional Feature: Grind Gap Control, Feeder, Batcher
- FOB Price: USD 30,000-50,000
- Gross Weight: ~ 6 ton

Machineries Supplier:

- Bangladesh Hardware & Machinery Merchants' Association (BHMMA), 5, Bangabandu Avenue (3rd Floor), Dhaka. Tel: +8802-9569783. Mobile: +8801924-424085.
- China Bangla Engineers & Consultants Ltd. Mobile: +8801914-867929, +8801716-752370.
- National World Export & Import (Pvt.) Co. Ltd. Mobile: +8801684-949001.
- South Asia Trading. Tel: +8802-9667302, +8802-9667301.
- Osmonic BD Ltd. Tel: +8802-9571117, +8802-9563079.

Production Process Flow Chart:

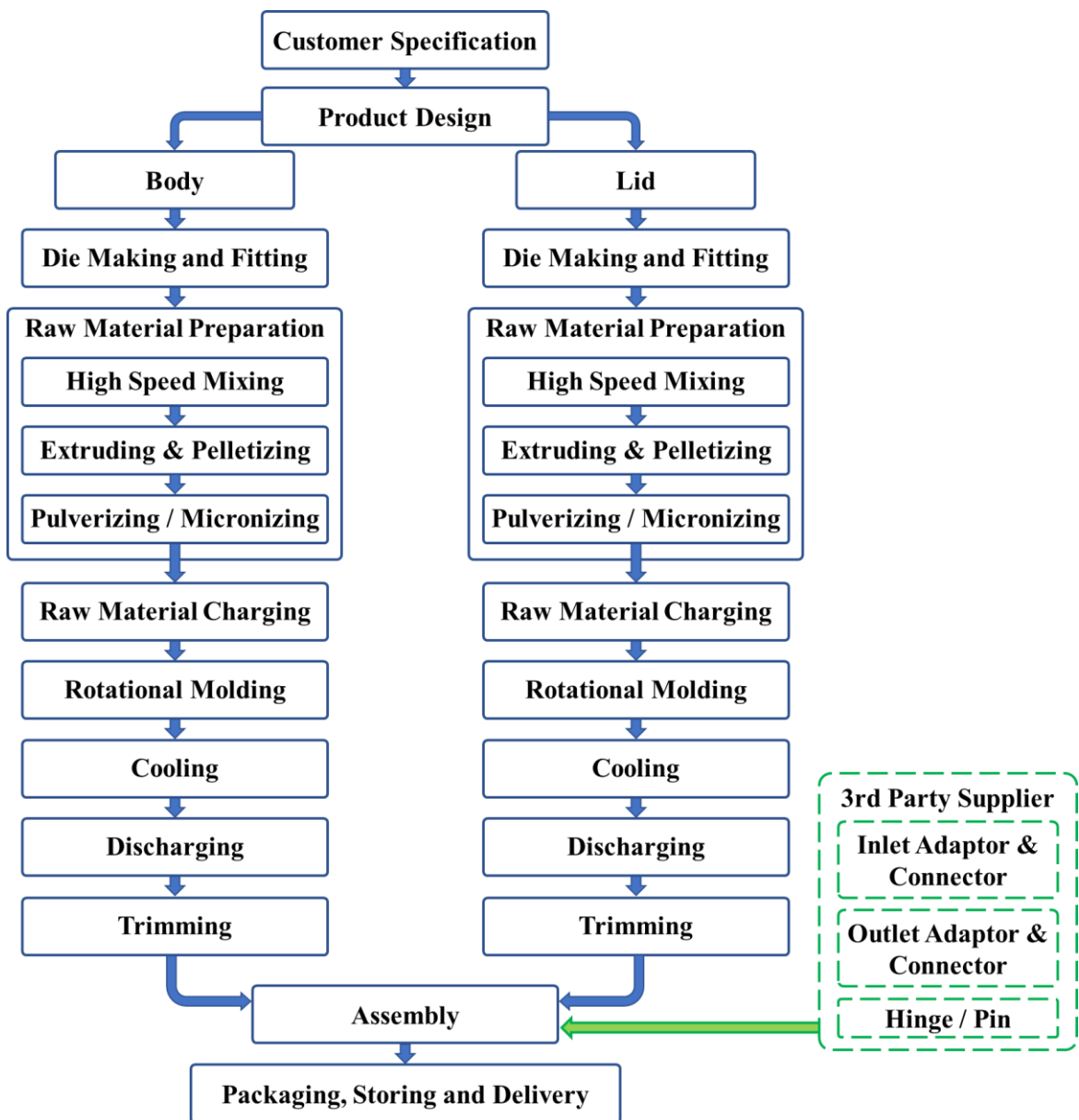

Die/Mold Supplier:

- Bangladesh Die & Mold Manufacturers Association, 220, New Elephant Road, Dhaka. Tel: +8802-961545415. Mobile: +8801711-526913.

Bibliography:

- Crawford, Roy J., Throne, James L., “Rotational Molding Technology”, William Andrew, 2003.
- Crawford, Roy J., Kearns, Mark P., “Practical Guide to Rotational Moulding”, Rapra Technology Limited, 2003.
- Beall, Glenn L., “Rotational Moulding: Design Materials Tooling and Processing”, Hanser Publications, 1998.

Product-02: Traffic Barrier

Sub-sector:	Building and Construction				
HS-2007:	3926.90.99	BSIC-2009:	2220	BCPC-2011:	36990

Description:
 A Traffic Barrier/ Jersey Barrier is a modular barrier with or without interlocking joint having hollow chamber either filled with water or sand or not. It is used as temporary barrier to separate and reroute traffic and pedestrians, ensure construction safety, control crowd, etc.

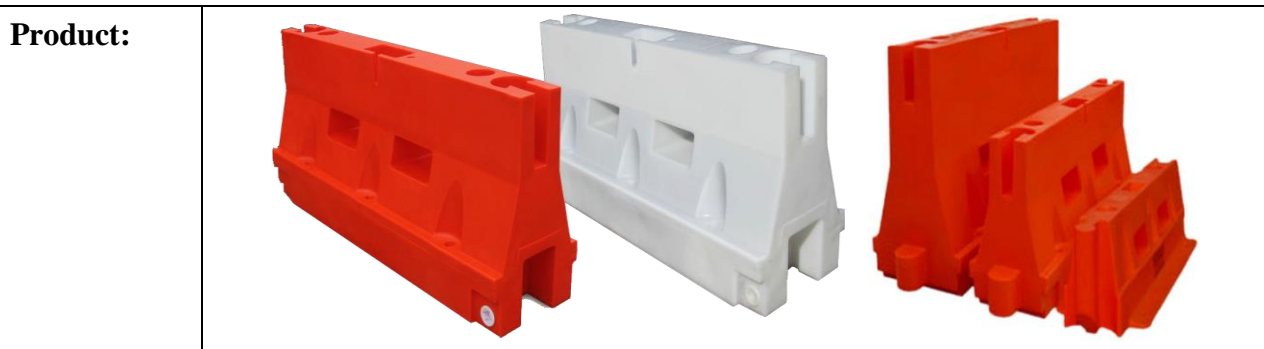

Raw Materials:	
Base Raw Material:	<ul style="list-style-type: none"> High Density Polyethylene (HDPE)
Additives:	<ul style="list-style-type: none"> Process Aid and Mold Release Pigment

Raw Material Supplier:

- Bangladesh Polymer Importers' Association, 315/B, Tejgaon I/A, Dhaka. Tel: +8802-9830149.
- Bangladesh Chemical Importers and Merchants Association, 124, Hazaribagh, Dhaka-1209. Tel: +8802-8622608, +8802-8624009. Mobile: +8801986-842486.
- Bangladesh Paint Dyes & Chemical Merchants' Association, F.R.Plaza, 18, Imamganj, Dhaka-1100. Mobile: +8801755-651207, +8801711-938123, +8801819-074794.

Machineries and Specification:

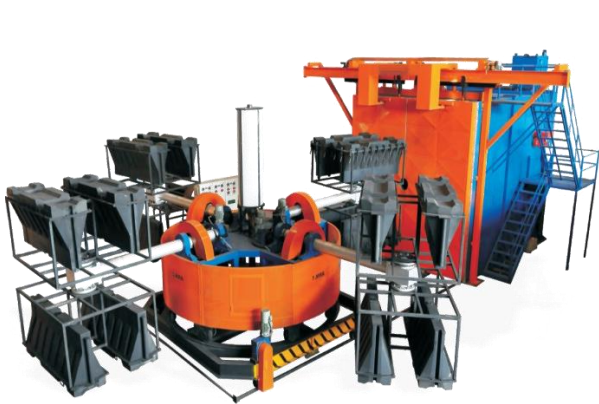
1. Carousel Type Rotational Molding Machine	
	<ul style="list-style-type: none"> No. of Arm: 4; Arm Type: Straight/ Offset Product Size (LxWxH): ~ 1.5 x 0.5 x 1 m Product Volume: Max. 50 L Mold Load Capacity: Max. 200 kg Heater Type: Burner (Gas/ Diesel) Cooler Type: Fan (Air/Mist) Oven Size (LxWxH): 3.5 x 2.5 x 3.5 m Power: ~ 20 kW (380V 3 Phase) Dimension (LxWxH): ~ 12 x 10 x 3.5 m FOB Price: USD 30,000-60,000 Gross Weight: ~ 10 ton

2. High Speed Mixer Machine



- Useful Volume: ~ 400 Liter
- Mixing Capacity: ~ 200 kg/hr
- Motor Power: ~ 80 HP
- Speed: ~ 5 Variable Speed
- Power: 70 kW (380V 3 Phase)
- Dimension (LxWxH): ~ 3 x 1.5 x 2.5 m
- Optional Feature: Timer, Heater, PLC
- FOB Price: USD 3,500-6,000
- Gross Weight: ~ 2 ton

3. Pellet Extruder Machine



- Screw Dia.: ~50 mm
- Screw Length: ~ 200 mm
- Screw L/D: 35-70
- Power: ~ 60 kW
- Production Capacity: ~ 180-225 kg/hr
- Dimension (LxWxH): ~ 3 x 2.5 x 2 m
- Optional Feature: Dryer, Feeder
- FOB Price: USD 25,000-40,000
- Gross Weight: ~ 3.5 ton

4. Pulverizing / Micronizing Machine



- No. of Mills: 1
- Grinding Media: Disk (2 double faced taper)
- Sifter Type: Centrifugal
- Total Sifter Area (3decks): ~ 1,800 sq. in.
- Production Rate (30 Mesh): ~ 450 kg/hr
- Power: ~ 50 kW
- Dimension (LxWxH): ~ 2.5 x 2 x 5 m
- Optional Feature: Grind Gap Control, Feeder
- FOB Price: USD 25,000-40,000
- Gross Weight: ~ 5 ton

Machineries Supplier:

- Bangladesh Hardware & Machinery Merchants' Association (BHMMA), 5, Bangabandu Avenue (3rd Floor), Dhaka. Tel: +8802-9569783. Mobile: +8801924-424085.
- China Bangla Engineers & Consultants Ltd. Mobile: +8801914-867929, +8801716-752370.
- National World Export & Import (Pvt.) Co. Ltd. Mobile: +8801684-949001.
- South Asia Trading. Tel: +8802-9667302, +8802-9667301.
- Osmonic BD Ltd. Tel: +8802-9571117, +8802-9563079.

Production Process Flow Chart:

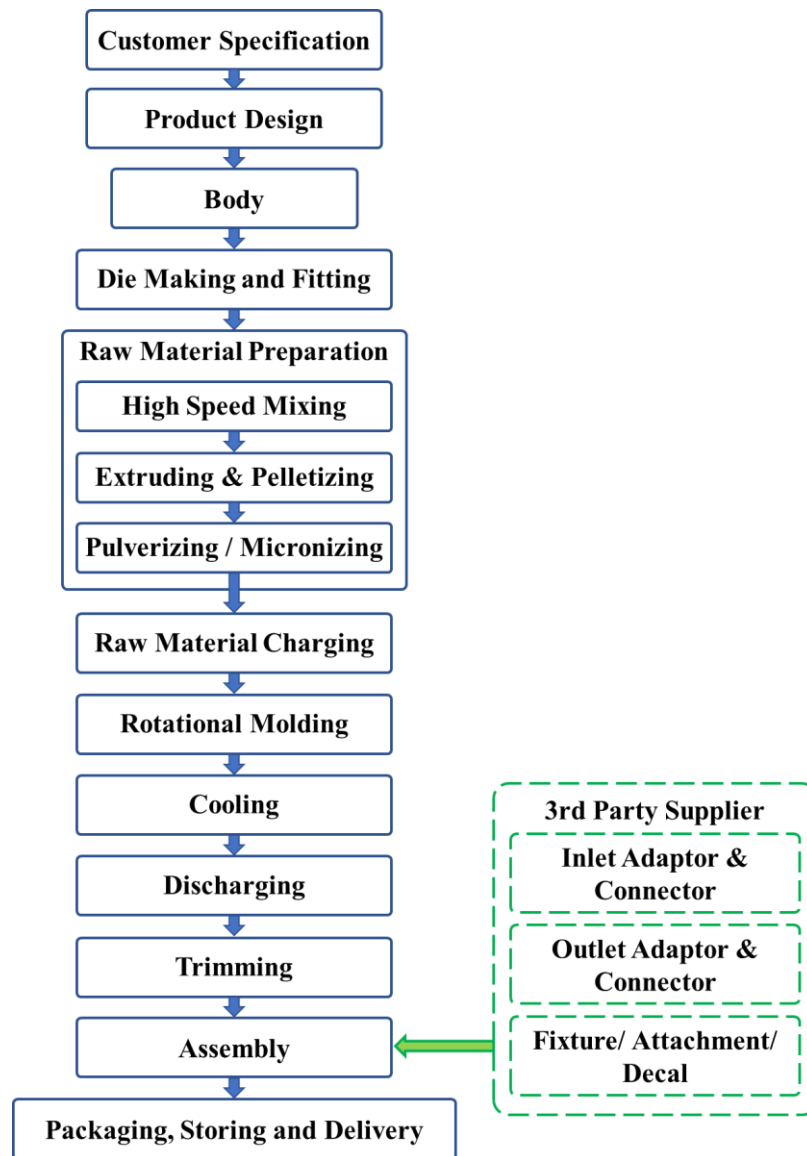

Die/Mold Supplier:

- Bangladesh Die & Mold Manufactures Association, 220, New Elephant Road, Dhaka. Tel: +8802-961545415. Mobile: +8801711-526913.

Bibliography:

- Crawford, Roy J., Throne, James L., “Rotational Molding Technology”, William Andrew, 2003.
- Crawford, Roy J., Kearns, Mark P., “Practical Guide to Rotational Moulding”, Rapra Technology Limited, 2003.
- Beall, Glenn L., “Rotational Moulding: Design Materials Tooling and Processing”, Hanser Publications, 1998.

Product-03: Ice Cooler

Sub-sector: Household, Tableware & Kitchenware

HS-2007: 8418.50.90

BSIC-2009: 2819

BCPC-2011: 43913

Description:

An Ice Cooler/ Chest Cooler/ Ice Box cooler is a portable insulated box used to keep food or drink cool with application of ice or ice packs.

Product:



Raw Materials:

Base Raw Material:	<ul style="list-style-type: none"> High Density Polyethylene (HDPE) Low Density Polyethylene (LDPE)
Additives:	<ul style="list-style-type: none"> Process Aid and Mold Release Pigment

Raw Material Supplier:

- Bangladesh Polymer Importers' Association, 315/B, Tejgaon I/A, Dhaka. Tel: +8802-9830149.
- Bangladesh Chemical Importers and Merchants Association, 124, Hazaribagh, Dhaka-1209. Tel: +8802-8622608, +8802-8624009. Mobile: +8801986-842486.
- Bangladesh Paint Dyes & Chemical Merchants' Association, F.R.Plaza, 18, Imamganj, Dhaka-1100. Mobile: +8801755-651207, +8801711-938123, +8801819-074794.

Machineries and Specification:

1. Shuttle Type Rotational Molding Machine



- No. of Arm: 1; Arm Type: Straight/ Offset/ C
- Product Size (LxWxH): ~ 0.9 x 0.6 x 0.4 m
- Product Volume: Max. 70 L
- Mold Load Capacity: Max. 150 kg
- Heater Type: Burner (Gas/ Diesel)
- Cooler Type: Fan (Air)
- Oven Size (LxWxH): 3.5 x 2.5 x 3.5 m
- Power: ~ 15 kW (380V 3 Phase)
- Dimension (LxWxH): ~ 8 x 5 x 3.5 m
- FOB Price: USD 25,000-45,000
- Gross Weight: ~ 8 ton

2. High Speed Mixer Machine



- Useful Volume: ~ 350 Liter
- Mixing Capacity: ~ 180 kg/hr
- Motor Power: ~ 90 HP
- Speed: ~ 2 Variable Speed
- Power: 80 kW (380V 3 Phase)
- Dimension (LxWxH): ~ 2.5 x 1.5 x 2.5 m
- Optional Feature: Timer, Heater, PLC
- FOB Price: USD 3,000-8,000
- Gross Weight: ~ 2 ton

3. Pellet Extruder Machine



- Screw Dia.: ~60 mm
- Screw Length: ~ 230 mm
- Screw L/D: 32-60
- Power: ~ 30 kW
- Production Capacity: ~ 180-225 kg/hr
- Dimension (LxWxH): ~ 4 x 5 x 2 m
- Optional Feature: Dryer, Feeder
- FOB Price: USD 25,000-40,000
- Gross Weight: ~ 5 ton

4. Pulverizing / Micronizing Machine



- No. of Mills: 1
- Grinding Media: Disk (2 double faced taper)
- Sifter Type: Centrifugal
- Total Sifter Area (3 decks): ~ 1,500 sq. in.
- Production Rate (30 Mesh): ~ 500 kg/hr
- Power: ~ 45 kW
- Dimension (LxWxH): ~ 2 x 2 x 4.5 m
- Optional Feature: Grind Gap Control, Feeder
- FOB Price: USD 25,000-40,000
- Gross Weight: ~ 3.5 ton

5. Foam Filling Machine



- No. of Tanks: 3 (2 Component, 1 Solvent)
- Tank Capacity: ~ 100, 100, 20 L
- Working Pressure: Max. 150 psi
- Working Temperature: Max. 90 °C
- Tank Mixing: Shear Stirrer (Max. 5,000 rpm)
- Feed Pumps: Metering Type
- Mixing Head: Recycle Type
- Injection Rate: 0.2 – 2.5 L/min
- Heating Capacity: ~ 6 kW
- Cooling Capacity: ~ 3 kW
- Power: ~ 12 kW (400V, 3 Phase)
- Gross Weight: ~ 800 kg

Machineries Supplier:

- Bangladesh Hardware & Machinery Merchants' Association (BHMMA), 5, Bangabandu Avenue (3rd Floor), Dhaka. Tel: +8802-9569783. Mobile: +8801924-424085.
- China Bangla Engineers & Consultants Ltd. Mobile: +8801914-867929, +8801716-752370.

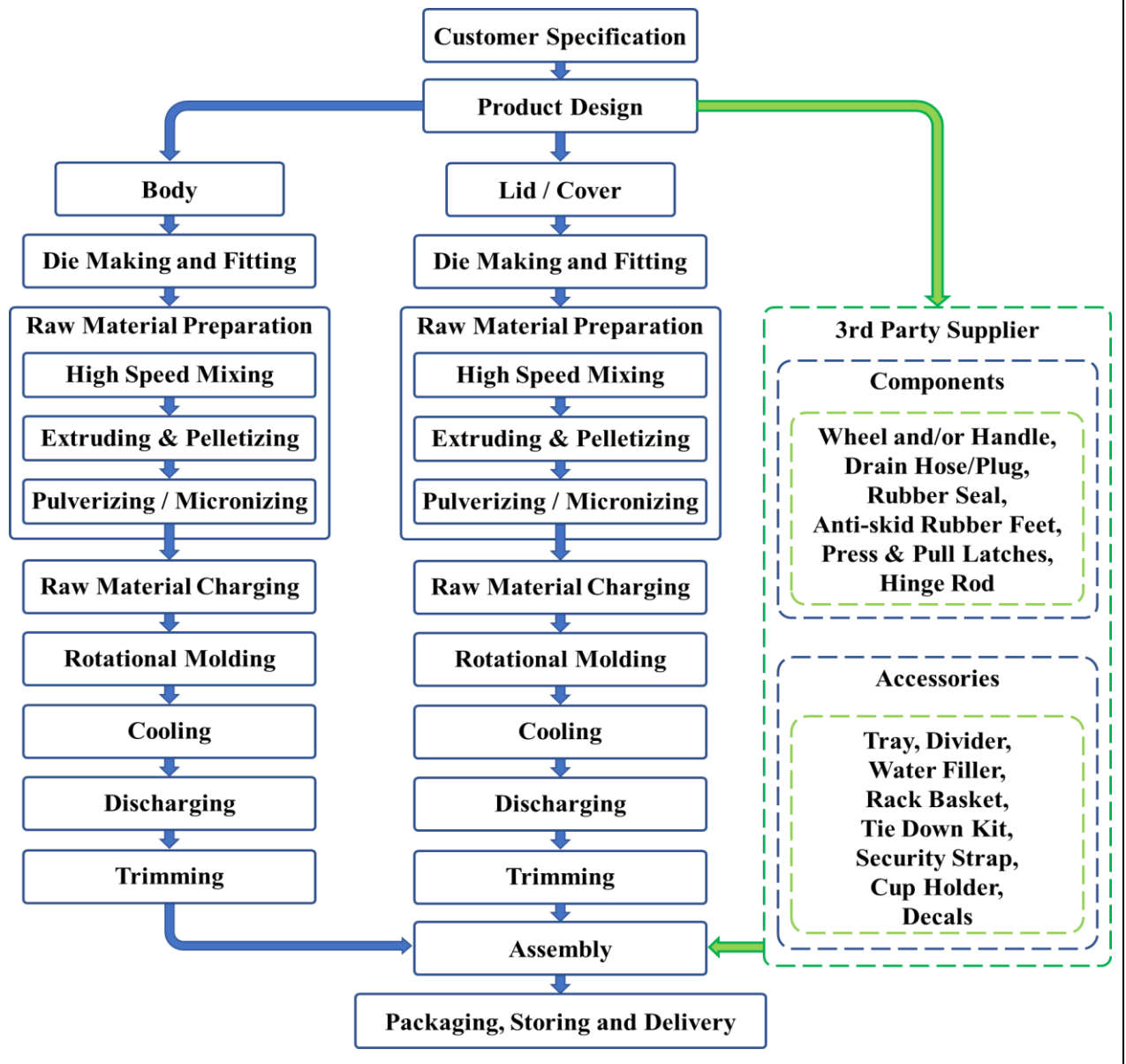
Production Process Flow Chart:**Die/Mold Supplier:**

- Bangladesh Die & Mold Manufactures Association, 220, New Elephant Road, Dhaka. Tel: +8802-961545415. Mobile: +8801711-526913.

Bibliography:

- Crawford, Roy J., Throne, James L., "Rotational Molding Technology", William Andrew, 2003.
- Crawford, Roy J., Kearns, Mark P., "Practical Guide to Rotational Moulding", Rapra Technology Limited, 2003.

Chapter 5: Thermoforming

Thermoforming Process

Introduction:

Thermoforming is a manufacturing process of shell-type plastic goods in which a thermoplastic sheet is heated to its softening point, stretched over or into a mold, and held in place to cool and solidify into desired shape. The thermoforming process is most widely used in food packaging. Now-a-days, the process is used for production of toys, aircraft windscreen, cafeteria trays to automobile items.

The thermoforming process is categorized into three major classes, i.e.

- Vacuum forming: A vacuum is formed between the mold cavity and the thermoplastic sheet. The vacuum pressure (typically 14 psi) forces the sheet to conform to the mold and form the part shape.
- Pressure forming: In addition to utilizing a vacuum underneath the sheet, air pressure (typically 50 psi, but up to 100 psi) is applied on the back side of the sheet to help force it onto the mold. This additional force allows the forming of thicker sheets and creating finer details, textures, undercuts, and sharp corners.
- Mechanical forming: The thermoplastic sheet is mechanically forced into or around the mold by direct contact. Typically, a core plug will push the sheet into the mold cavity and force it into the desired shape.

These processes can also be incorporated into one another. Schematic representation of three types of thermoforming process are given below:

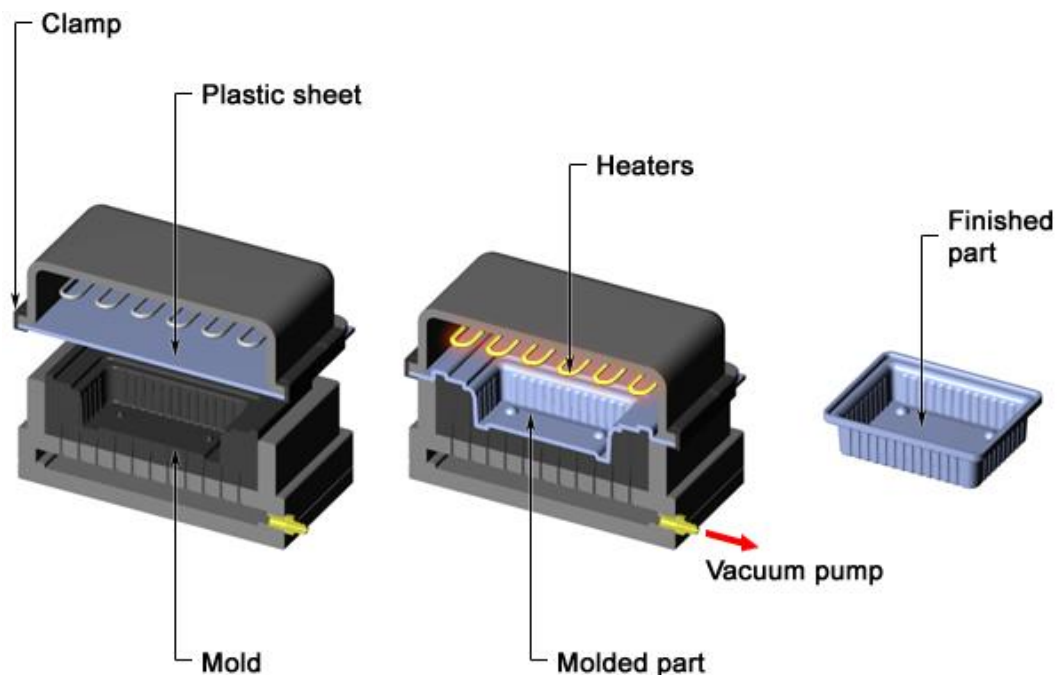

Fig. 7: Schematic representation of vacuum forming

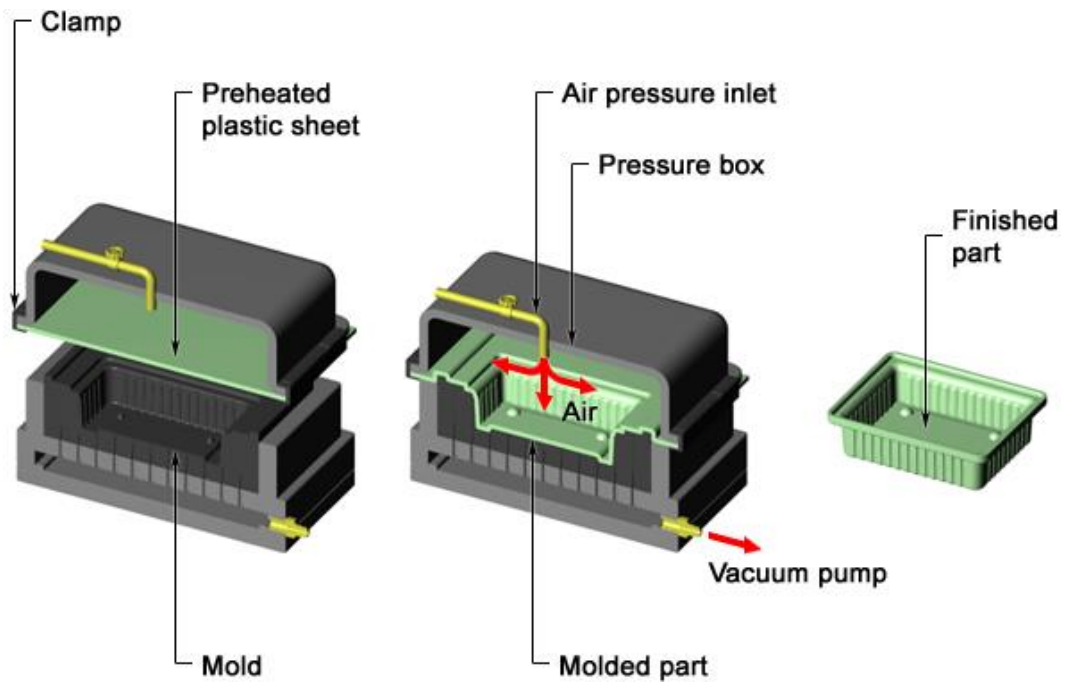

Fig. 8: Schematic representation of pressure forming

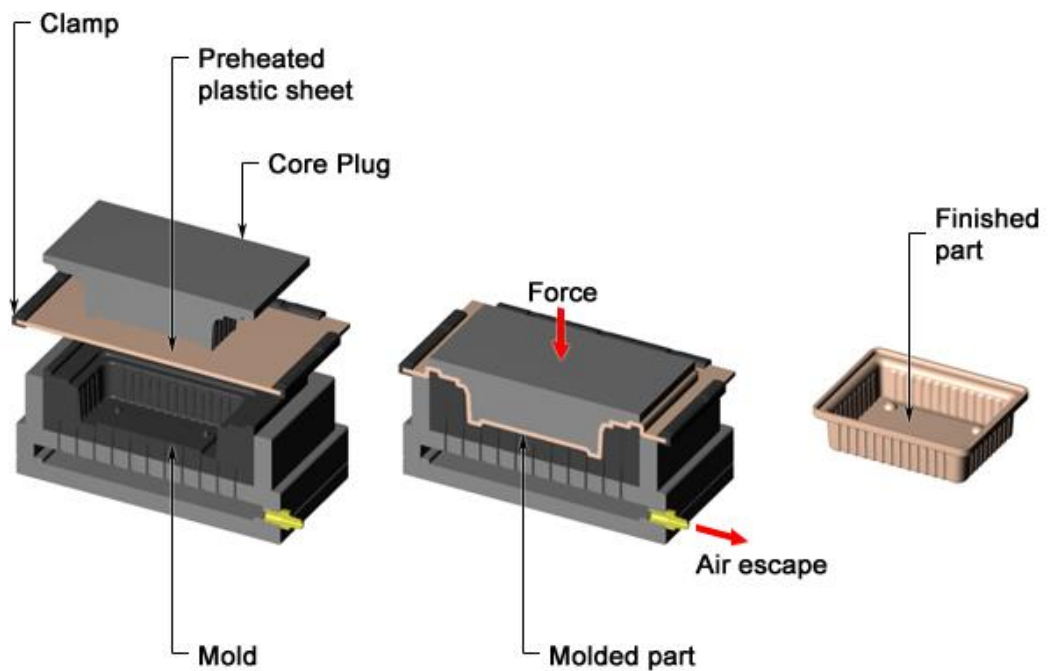

Fig. 9: Schematic representation of mechanical forming

Typical characteristics of thermoforming:

- Most favorable process for producing thin walled shell-type parts
- Possibility of producing one-piece part with no weld lines or joints
- Molds are inexpensive and require short manufacturing lead-time
- Limited capability in terms of part shape complexity and scrap recycling
- Economically viable for short production runs

Possible defects and methods of elimination:

Sl.	Defect	Cause	Solution
1	Blisters or Bubbles	<ul style="list-style-type: none"> • Overheating or rapid heating • Excessive moisture • Uneven Heating 	<ul style="list-style-type: none"> • Lower the heater temperatures or reduce the top heater if using twin heating. • Pre-dry/ Pre-heat sheet. Heat from both sides. Keep material wrapped until ready to use. • Check consumption. Increase zone control
2	Poor Mold Release	<ul style="list-style-type: none"> • Mold or part too hot • Mold undercuts • Insufficient draft angles • Poor mold surface 	<ul style="list-style-type: none"> • Increase cooling cycle. Decrease mold temperature • Increase release time and pressure. • Increase draft. And convert mold to female • Use mold release. Improve mold surface.
3	Sheet Scorching	<ul style="list-style-type: none"> • Top/Bottom surface too hot 	<ul style="list-style-type: none"> • Decrease heating cycle time. • Decrease heater temp. • Check for faulty heat zones if problem in isolated area. • Pre-heat material.
4	Lack of Definition	<ul style="list-style-type: none"> • Material too cold • Mold too cold • Insufficient vacuum 	<ul style="list-style-type: none"> • Increase heating time and temperature. • Increase heater density or wattage. • Ensure mold is at optimum temperature for forming. • Adjust vacuum timings. • Check leakage or obstruction to vent • Increase vacuum capacity
5	Webbing	<ul style="list-style-type: none"> • Material too hot • Insufficient vacuum • Incorrect pre-stretch height • Excess material • Poor mold design • Vacuum speed too fast 	<ul style="list-style-type: none"> • Shorten cycle time. Lower heater temperature. • Check system for leaks. • Increase size of vacuum holes. • Check for blocked holes • Adjust pre-stretch flow and time. • Reduce material size and use reducing windows. • Increase radii and improve draw ratios. • Use plug/ ring assist. Use assist blocks to pull out webbing. • Increase spacing between mold. • Switch to female mold.

References:

- Ebnesajjad, Sina, “Plastic Films in Food Packaging: Materials, Technology and Applications”, William Andrew, 2013.
- Ashter, Syed Ali, “Thermoforming of Single and Multilayer Laminates: Plastic Films Technologies, Testing, and Applications”, William Andrew Publishing, 2013.
- Illig, Adolf, “Thermoforming: A Practical Guide”, Hanser Gardner Publications, 2001.
- Gruenwald, Geza, “Thermoforming”, CRC Press, 1995.
- Throne, James L., “Understanding Thermoforming”, Hanser Gardner Publications, 2008.
- Klein, Peter W., “Fundamentals of Plastics Thermoforming”, Morgan & Claypool Publishers, 2009.
- Rosen, Stanley R., “Thermoforming: Improving Process Performance”, Society of Manufacturing Engineers, 2002.
- Engelmann, Sven, “Advanced Thermoforming: Methods, Machines and Materials, Applications and Automation”, John Wiley & Sons, 2012.

Thermoformed Products

Product-01: Disposable Cup

Sub-sector: Packaging

HS-2007: 3926.90.99

BSIC-2009: 2220

BCPC-2011: 36990

Description:

A disposable cup is a type of cone-shaped individual use/ one-time use tableware and/or food packaging mostly utilized to contain water and beverages.

Product:



Raw Materials:

Base Raw Material:	<ul style="list-style-type: none"> High Impact Polystyrene (HIPS) Polystyrene (PS) 	<ul style="list-style-type: none"> Polyethylene Terephthalate (PET) Polyvinyl Chloride (PVC)
Additives:	<ul style="list-style-type: none"> Process Aid and Mold Release 	<ul style="list-style-type: none"> Pigment

Raw Material Supplier:

- Bangladesh Polymer Importers' Association, 315/B, Tejgaon I/A, Dhaka. Tel: +8802-9830149.
- Bangladesh Chemical Importers and Merchants Association, 124, Hazaribagh, Dhaka-1209. Tel: +8802-8622608, +8802-8624009. Mobile: +8801986-842486.
- Bangladesh Paint Dyes & Chemical Merchants' Association, F.R.Plaza, 18, Imamganj, Dhaka-1100. Mobile: +8801755-651207, +8801711-938123, +8801819-074794.

Machineries and Specification:

1. Sheet Extrusion Machine



- Product Size (WxT): ~ 1,000 x 2 mm
- Production Rate: ~ 150-200 kg/hr
- Thrust Bearing Dynamic Load: ~ 50 ton
- Screw Dia.: 110 mm
- Screw L/D Ratio: 32:1
- Power: ~ 55 kW (400V 3 Phase)
- Dimension (LxWxH): ~ 4 x 2 x 3 m
- Optional Feature: Dryer, Feeder
- FOB Price: USD 45,000-70,000
- Gross Weight: ~ 5 ton

2. Polishing Stack and Haul Off Machine



- Sheet Thickness: ~ 0.25 – 10 mm
- Sheet Width: ~ 1 – 2 m
- Number of Polishing Roll: 6
- Polishing Roll Dia.: ~ 400 – 500 mm
- Speed: ~ 0.1 – 10 m/min
- Haul-off Traction: Double strand
- Power: ~ 25 kW (400V 3 Phase)
- Dimension (LxWxH): ~ 8 x 2.5 x 2.5 m
- FOB Price: USD 25,000-40,000
- Gross Weight: ~ 4 ton

3. Winding Machine



- Sheet Thickness: ~ 0.25 – 15 mm
- Sheet Width: ~ 1 – 2 m
- Number of Winding Roll: 3
- Speed: ~ 5 – 40 m/min
- Power: ~ 10 kW (400V 3 Phase)
- Dimension (LxWxH): ~ 3 x 3 x 3 m
- FOB Price: USD 7,000-8,000
- Gross Weight: ~ 2.5 ton

4. Thermoforming Machine



- Sheet Thickness: ~ 0.25 – 2 mm
- Sheet Width: ~ 1.2 m
- Forming Method: Vacuum / Pressure
- Forming Direction: Upper Sheet Forming
- Forming Area: ~ 1,000 x 1,000 mm
- Draw Depth: Max. 150 mm
- Clamping Force: ~ 60 ton
- Dry Cycle Speed: ~ 30 cycle/min
- Stations: Heating, Forming, Cutting
- Power: ~ 60 kW (400V 3 Phase)
- Dimension (LxWxH): ~ 7 x 2.5 x 3 m
- FOB Price: USD 40,000-65,000
- Gross Weight: ~ 5 ton

5. Mixing Machine



- Mixing Capacity: 100 kg/hr (250 l)
- Motor Power: ~ 2-4 HP
- Rotating Speed: ~ 90 rpm
- Power: ~ 3 kW (400V 3 Phase)
- Dimension (LxWxH): ~ 1 x 0.8 x 0.85 m
- Optional Feature: Timing Device, Heater
- FOB Price: USD 500-1,500
- Gross Weight: 150-200 kg

Machineries Supplier:

- Bangladesh Hardware & Machinery Merchants' Association (BHMMA), 5, Bangabandu Avenue (3rd Floor), Dhaka. Tel: +8802-9569783. Mobile: +8801924-424085.
- China Bangla Engineers & Consultants Ltd. Mobile: +8801914-867929, +8801716-752370.

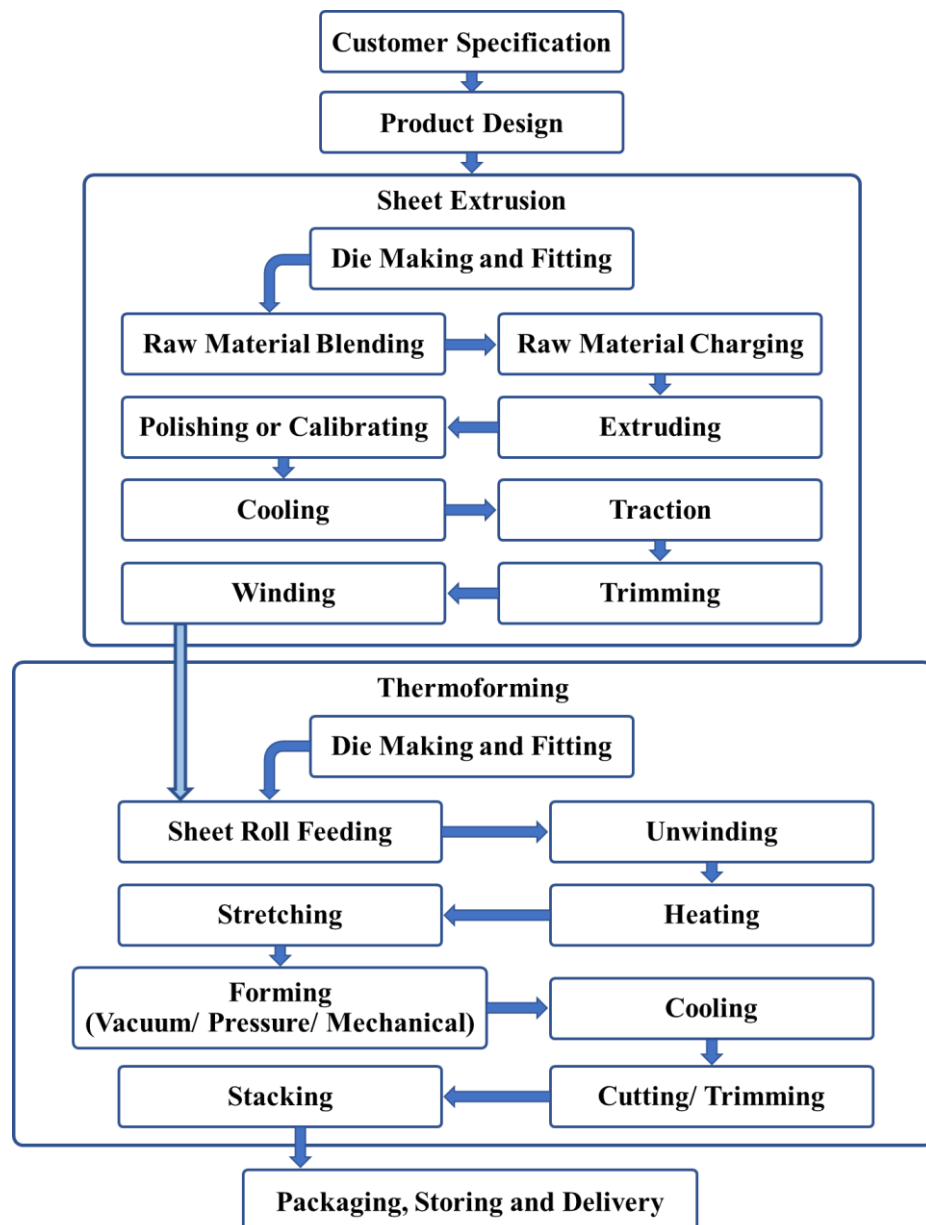
Production Process Flow Chart:**Die/Mold Supplier:**

- Bangladesh Die & Mold Manufactures Association, 220, New Elephant Road, Dhaka. Tel: +8802-961545415. Mobile: +8801711-526913.

Bibliography:

- Ebnesajjad, Sina, "Plastic Films in Food Packaging: Materials, Technology and Applications", William Andrew, 2013.
- Ashter, Syed Ali, "Thermoforming of Single and Multilayer Laminates: Plastic Films Technologies, Testing, and Applications", William Andrew Publishing, 2013.

Product-02: Packaging Tray

Sub-sector:	Packaging				
HS-2007:	3923.90.90	BSIC-2009:	2220	BCPC-2011:	36490

Description:
 A packaging tray is a single/multi-compartment flat/shallow container with a raised rim having simple/complex cavity design used to hold and protect items (food and non-food).



Raw Materials:	
Base Raw Material:	<ul style="list-style-type: none"> • High Impact Polystyrene (HIPS) • Polyethylene Terephthalate (PET/RPET/PETG) • Polyvinyl Chloride (PVC)
Additives:	<ul style="list-style-type: none"> • Process Aid and Mold Release • Pigment

Raw Material Supplier:

- Bangladesh Polymer Importers' Association, 315/B, Tejgaon I/A, Dhaka. Tel: +8802-9830149.
- Bangladesh Chemical Importers and Merchants Association, 124, Hazaribagh, Dhaka-1209. Tel: +8802-8622608, +8802-8624009. Mobile: +8801986-842486.
- Bangladesh Paint Dyes & Chemical Merchants' Association, F.R.Plaza, 18, Imamganj, Dhaka-1100. Mobile: +8801755-651207, +8801711-938123, +8801819-074794.

Machineries and Specification:

1. Sheet Extrusion Machine

	<ul style="list-style-type: none"> • Product Size (WxT): ~ 1,000 x 2 mm • Production Rate: ~ 200-250 kg/hr • Thrust Bearing Dynamic Load: ~ 70 ton • Screw Dia.: 120 mm • Screw L/D Ratio: 35:1 • Power: ~ 65 kW (400V 3 Phase) • Dimension (LxWxH): ~ 4 x 2 x 3 m • Optional Feature: Dryer, Feeder • FOB Price: USD 35,000-60,000 • Gross Weight: ~ 4.5 ton
---	---

2. Polishing Stack and Haul Off Machine



- Sheet Thickness: ~ 0.25 – 5 mm
- Sheet Width: ~ 1 – 1.5 m
- Number of Polishing Roll: 3
- Polishing Roll Dia.: ~ 450 – 500 mm
- Speed: ~ 0.1 – 15 m/min
- Haul-off Traction: Double strand
- Power: ~ 30 kW (400V 3 Phase)
- Dimension (LxWxH): ~ 7.5 x 3.5 x 3 m
- FOB Price: USD 25,000-45,000
- Gross Weight: ~ 4 ton

3. Winding Unit



- Sheet Thickness: ~ 0.25 – 10 mm
- Sheet Width: ~ 1 – 1.5 m
- Number of Winding Roll: 1
- Speed: ~ 5 – 30 m/min
- Power: ~ 8 kW (400V 3 Phase)
- Dimension (LxWxH): ~ 3 x 2.5 x 2.5 m
- FOB Price: USD 7,000-8,000
- Gross Weight: ~ 2 ton

4. Thermoforming Machine



- Sheet Thickness: ~ 0.25 – 2 mm
- Sheet Width: ~ 1 m
- Forming Method: Vacuum/Pressure w/o plug
- Forming Area: ~ 800 x 700 mm
- Draw Depth: ~ 150 mm
- Clamping Cutting Force: ~ 75 ton
- Air Pressure: 06 – 1 MPa
- Water Consumption: 60 – 200 l/min
- Dry Cycle Speed: ~ 45 cpm
- Power: ~ 50 kW (400V 3 Phase)
- Dimension (LxWxH): ~ 15 x 4 x 3.5 m
- FOB Price: USD 50,000-1,20,000
- Gross Weight: ~ 8 ton

5. Mixing Machine



- Mixing Capacity: 100 kg/hr (250 l)
- Motor Power: ~ 2-4 HP
- Rotating Speed: ~ 90 rpm
- Power: ~ 3 kW (400V 3 Phase)
- Dimension (LxWxH): ~ 1 x 0.8 x 0.85 m
- Optional Feature: Timing Device, Heater
- FOB Price: USD 500-1,500
- Gross Weight: 150-200 kg

Machineries Supplier:

- Bangladesh Hardware & Machinery Merchants' Association (BHMMA), 5, Bangabandu Avenue (3rd Floor), Dhaka. Tel: +8802-9569783. Mobile: +8801924-424085.
- China Bangla Engineers & Consultants Ltd. Mobile: +8801914-867929, +8801716-752370.

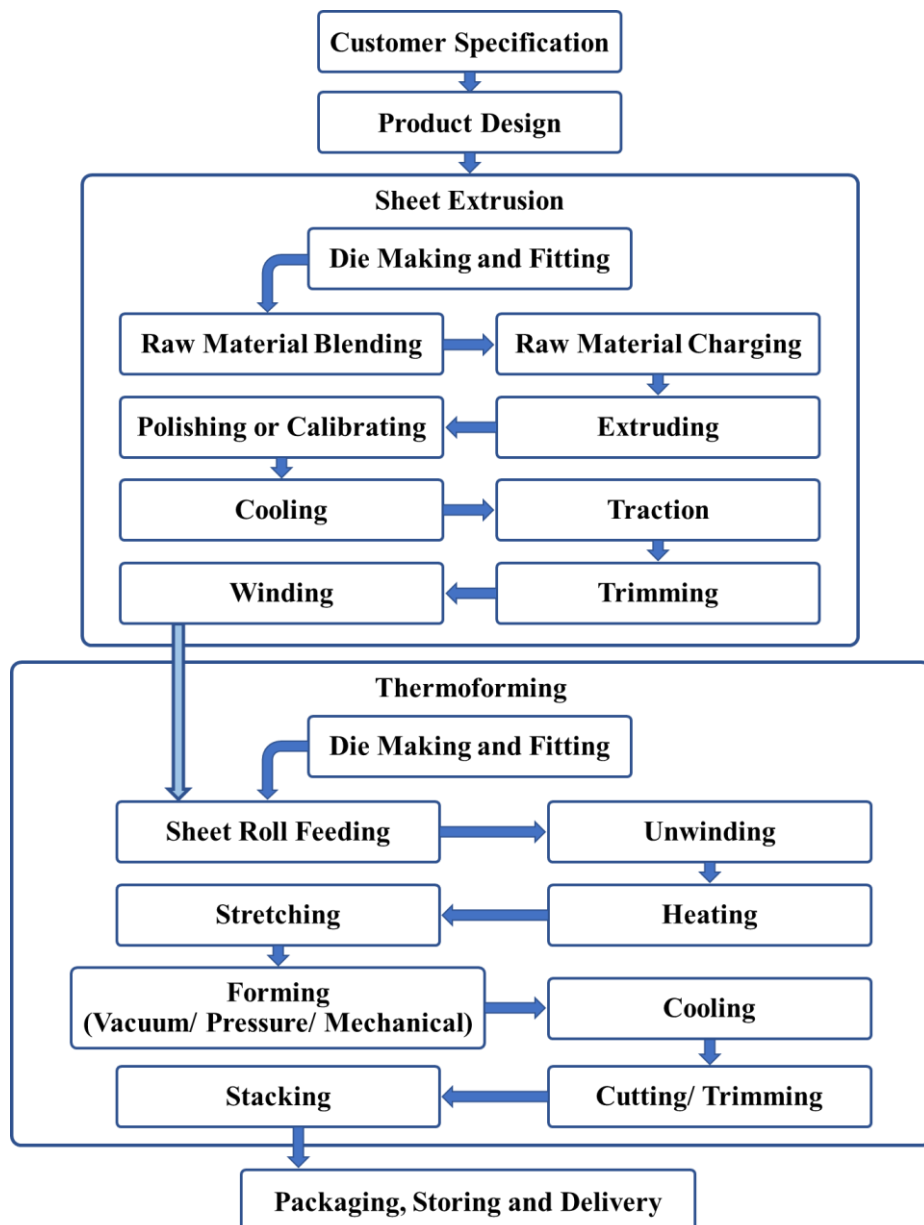
Production Process Flow Chart:**Die/Mold Supplier:**

- Bangladesh Die & Mold Manufactures Association, 220, New Elephant Road, Dhaka. Tel: +8802-961545415. Mobile: +8801711-526913.

Bibliography:

- Ebnesajjad, Sina, "Plastic Films in Food Packaging: Materials, Technology and Applications", William Andrew, 2013.
- Ashter, Syed Ali, "Thermoforming of Single and Multilayer Laminates: Plastic Films Technologies, Testing, and Applications", William Andrew Publishing, 2013.

Product-03: Air Bubble Film

Sub-sector:	Packaging				
HS-2007:	3923.90.90	BSIC-2009:	2220	BCPC-2011:	36490

Description:
An Air Bubble Film/ Bubble Wrap/ Cushioning Laminate is a flexible packing consisting of two plastic sheets laminated together in a way that traps air bubbles in small and uniform pockets.



Raw Materials:

Base Raw Material:	<ul style="list-style-type: none"> • Polyethylene (PE) • Nylon (Polyamides) 	<ul style="list-style-type: none"> • Polypropylene (PP)
Additives:	<ul style="list-style-type: none"> • Process Aid and Mold Release 	<ul style="list-style-type: none"> • Pigment

Raw Material Supplier:

- Bangladesh Polymer Importers' Association, 315/B, Tejgaon I/A, Dhaka. Tel: +8802-9830149.
- Bangladesh Chemical Importers and Merchants Association, 124, Hazaribagh, Dhaka-1209. Tel: +8802-8622608, +8802-8624009. Mobile: +8801986-842486.
- Bangladesh Paint Dyes & Chemical Merchants' Association, F.R.Plaza, 18, Imamganj, Dhaka-1100. Mobile: +8801755-651207, +8801711-938123, +8801819-074794.

Machineries and Specification:

1. Sheet Extrusion Machine

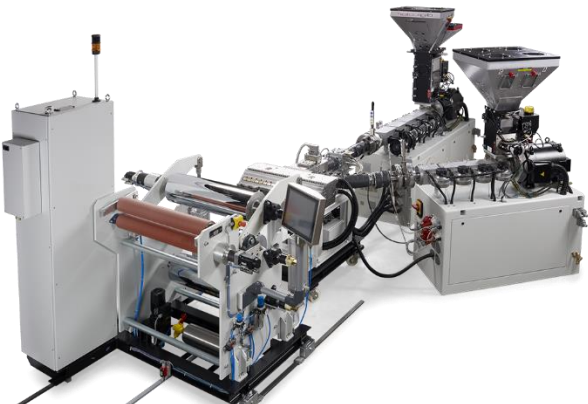
	<ul style="list-style-type: none"> • No. of Extrusion Layer: 2 • Product Size (WxT): ~ 1,000 x 2 mm • Production Rate: ~ 150-200 kg/hr • Screw Dia.: 110 mm • Screw L/D Ratio: 32:1 • Power: ~ 70 kW (400V 3 Phase) • Dimension (LxWxH): ~ 5 x 3.5 x 2.5 m • Optional Feature: Dryer, Feeder • FOB Price: USD 50,000-80,000 • Gross Weight: ~ 7 ton
---	---

2. Calibration, Forming and Haul Off Machine

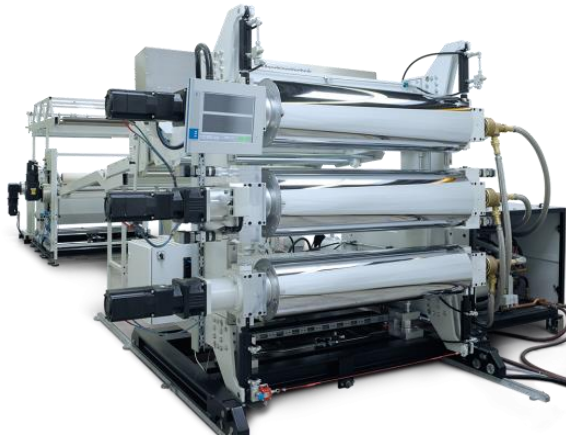

- Sheet Thickness: ~ 0.25 – 10 mm
- Sheet Width: ~ 1 – 2 m
- Number of Polishing Roll: 6
- Polishing Roll Dia.: ~ 400 – 500 mm
- Speed: ~ 0.1 – 10 m/min
- Forming Type: Vacuum Drum
- Haul-off Traction: Double strand
- Power: ~ 25 kW (400V 3 Phase)
- Dimension (LxWxH): ~ 8 x 2.5 x 2.5 m
- FOB Price: USD 25,000-40,000
- Gross Weight: ~ 4 ton

3. Winding and Slitting Machine



- Sheet Thickness: ~ 0.25 – 15 mm
- Sheet Width: ~ 1 – 2 m
- Number of Winding Roll: 3
- Cutting Type: Rotary Blade
- Speed: ~ 5 – 40 m/min
- Power: ~ 10 kW (400V 3 Phase)
- Dimension (LxWxH): ~ 3 x 3 x 3 m
- FOB Price: USD 7,000-8,000
- Gross Weight: ~ 2.5 ton

4. Mixing/ Blending Machine



- Mixing Capacity: 100 kg/hr (250 l)
- Motor Power: ~ 2-4 HP
- Rotating Speed: ~ 90 rpm
- Power: ~ 3 kW (400V 3 Phase)
- Dimension (LxWxH): ~ 1 x 0.8 x 0.85 m
- Optional Feature: Timing Device, Heater
- FOB Price: USD 500-1,500
- Gross Weight: 150-200 kg

Machineries Supplier:

- Bangladesh Hardware & Machinery Merchants' Association (BHMMA), 5, Bangabandu Avenue (3rd Floor), Dhaka. Tel: +8802-9569783. Mobile: +8801924-424085.
- China Bangla Engineers & Consultants Ltd. Mobile: +8801914-867929, +8801716-752370.
- South Asia Trading. Tel: +8802-9667302, +8802-9667301.
- National World Export & Import (Pvt.) Co. Ltd. Mobile: +8801684-949001.
- Osmonic BD Ltd. Tel: +8802-9571117, +8802-9563079.

Production Process Flow Chart:

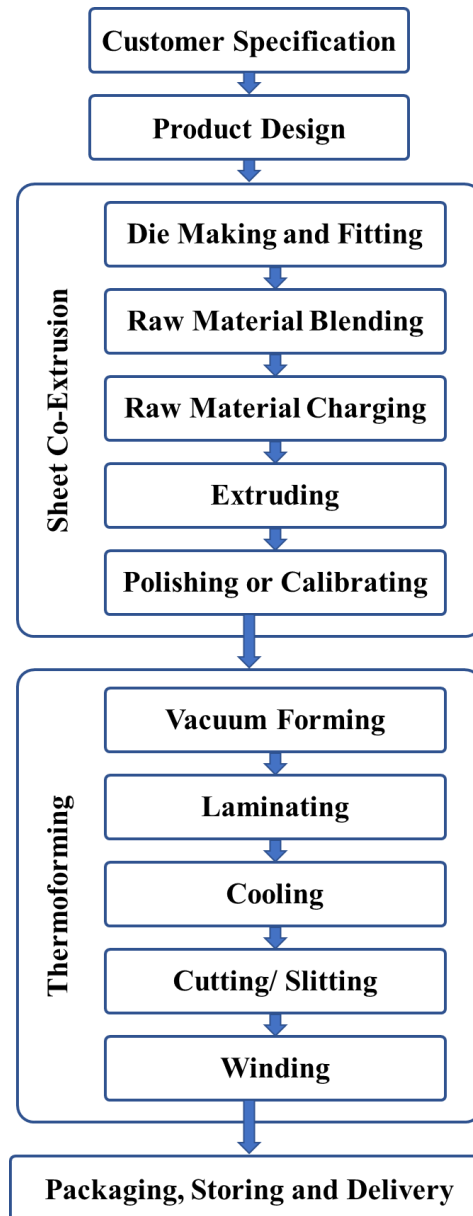

Die/Mold Supplier:

- Bangladesh Die & Mold Manufacturers Association, 220, New Elephant Road, Dhaka. Tel: +8802-961545415. Mobile: +8801711-526913.

Bibliography:

- Klein, Peter W., “Fundamentals of Plastics Thermoforming”, Morgan & Claypool Publishers, 2009.
- Rosen, Stanley R., “Thermoforming: Improving Process Performance”, Society of Manufacturing Engineers, 2002.
- Engelmann, Sven, “Advanced Thermoforming: Methods, Machines and Materials, Applications and Automation”, John Wiley & Sons, 2012.

Chapter 6: Compression Molding

Compression Molding Process

Introduction:

Compression molding is a manufacturing process in which a slug (compacted powder form) of plastic is vertically pressed between two heated mold halves. This process can produce parts with a wide array of lengths, thicknesses, and complexities. The objects it produces are also high in strength and have better aesthetics, which makes it an attractive process for many demanding applications in numerous industries. Schematic representation of three types of thermoforming process are given below:

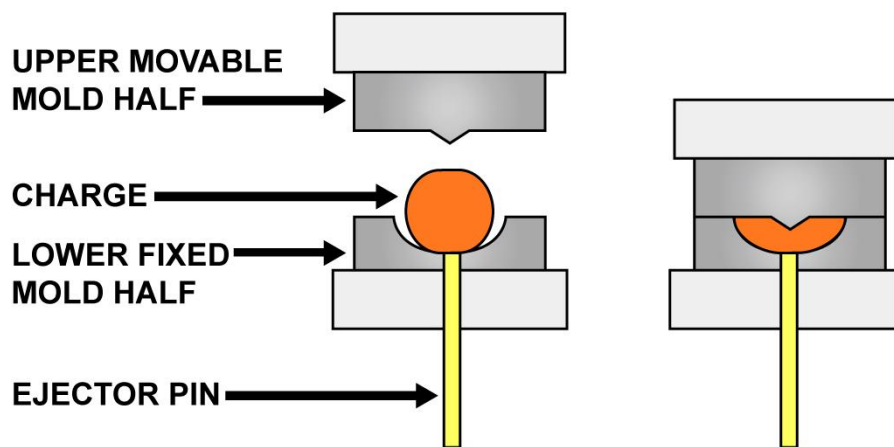

Fig. 10: Schematic representation of compression molding

Typical characteristics of compression molding:

- Most favorable process for parts with different reinforcements
- Lower pressure & temperature curing than autoclaves
- Relatively low tool costs and capital investment
- Ability to create very complex parts

Possible defects and methods of elimination:

Sl.	Defect	Cause	Solution
1	Cure Blisters	<ul style="list-style-type: none"> • Lack of preheat • Uneven Heating • Cold powder 	<ul style="list-style-type: none"> • Increase preheat temperature, decrease rate of preheat • Increase mold temperature • Increase cure time • Use minimum charge weight • Decrease mold closing speed
2	Excessive Flash	<ul style="list-style-type: none"> • Excessive charge material • Mold damage 	<ul style="list-style-type: none"> • Decrease charge weight • Increase preheat temperature • Increase mold temperature

			<ul style="list-style-type: none"> • Increase clamp tonnage • Check mold wear and change faulty mold
3	Flow Lines	<ul style="list-style-type: none"> • Improper material filling 	<ul style="list-style-type: none"> • Decrease mold temperature • Decrease preheat temperature • Decrease mold closing time
4	Mold Stains	<ul style="list-style-type: none"> • Volatile material buildup 	<ul style="list-style-type: none"> • Check mold venting • Polish the mold • Increase preheat temperature • Increase mold temperature • Decrease mold closing speed
5	Short Shots	<ul style="list-style-type: none"> • Improper mold filling due to porosity 	<ul style="list-style-type: none"> • Increase charge weight • Increase preheat temperature • Increase mold closing speed • Decrease mold temperature

References:

- Subramanian, M. N., “Compression Molding” in “Handbook of Troubleshooting Plastics Processes: A Practical Guide” (ed J. R. Wagner), John Wiley & Sons Inc., 2012.
- Davis, B., Gramann, P., Rios, A., Osswald, T., “Compression Molding”, Hanser Publications, 2003.
- Meyer, R.W., “Compression Molding Technology” in “Handbook of Polyester Molding Compounds and Molding Technology”, Springer, 1987.

Compression Molded Products

Product-01: Ceiling Rose

Sub-sector: Electrical and Electronic Equipment

HS-2007: 9405.10.00

BSIC-2009: 2740

BCPC-2011: 46531

Description:

A Ceiling Rose is a decorative element affixed to ceiling from which light fixture/ fitting is suspended.

Product:



Raw Materials:

Base Raw Material:	<ul style="list-style-type: none"> Fluorinated Ethylene Propylene (FEP) Ethylene-Tetrafluoroethylene (ETFE) Polyamide Imide (PAI)
Additives:	<ul style="list-style-type: none"> Process Aid and Mold Release Pigment

Raw Material Supplier:

- Bangladesh Polymer Importers' Association, 315/B, Tejgaon I/A, Dhaka. Tel: +8802-9830149.
- Bangladesh Chemical Importers and Merchants Association, 124, Hazaribagh, Dhaka-1209. Tel: +8802-8622608, +8802-8624009. Mobile: +8801986-842486.
- Bangladesh Paint Dyes & Chemical Merchants' Association, F.R.Plaza, 18, Imamganj, Dhaka-1100. Mobile: +8801755-651207, +8801711-938123, +8801819-074794.

Machineries and Specification:

1. Compression Molding Machine



- Clamping Force: ~ 200 ton
- Plate Size: ~ 500 x 600 mm
- Piston Diameter Stroke: ~ 350 mm/ 350 mm
- Daylight: 600 mm
- System Pressure: ~ 20 MPa
- Heating Capacity: ~ 15 kW
- Hydraulic Motor Capacity: ~ 10 HP
- Power: ~ 30 kW (400V 3 Phase)
- Dimension (LxWxH): ~ 2.1 x 1.2 x 2.4 m
- FOB Price: USD 8,000-20,000
- Gross Weight: ~ 5 ton

2. High Frequency/ Radio Frequency Preheating Machine



- Power: ~ 10 kW (400V 3 Phase)
- Oscillation Frequency: ~ 50 MHz
- Max. Input Power: ~ 15 kVA
- Electrode Size (LxW): ~ 0.4 x 0.4 m (Flat)
- Chamber Size (LxWxH): ~ 0.5 x 0.8 x 0.2 m
- Dimension (LxWxH): ~ 0.6 x 0.9 x 1.3 m
- FOB Price: USD 3,000-7,000
- Gross Weight: ~ 0.6 ton

3. Vibratory Deburring Machine



- Total Volume: ~ 850 l
- Deburring Media: Ceramic Chips
- Deburring Media Capacity: ~ 600 kg
- Bowl Width: ~ 450 mm
- Motor: 5 HP
- Output: Max. 1 ton/hr
- Power: ~ 4 kW
- Dimension (LxWxH): ~ 0.5 x 0.6 x 1.5 m
- FOB Price: USD 3,000-8,000
- Gross Weight: ~ 0.8 ton

4. Mixing/ Blending Machine



- Mixing Capacity: 100 kg/hr (250 l)
- Motor Power: ~ 2-4 HP
- Rotating Speed: ~ 90 rpm
- Power: ~ 3 kW (400V 3 Phase)
- Dimension (LxWxH): ~ 1 x 0.8 x 0.85 m
- Optional Feature: Timing Device, Heater
- FOB Price: USD 500-1,500
- Gross Weight: 150-200 kg

Machineries Supplier:

- Bangladesh Hardware & Machinery Merchants' Association (BHMMA), 5, Bangabandu Avenue (3rd Floor), Dhaka. Tel: +8802-9569783. Mobile: +8801924-424085.
- China Bangla Engineers & Consultants Ltd. Mobile: +8801914-867929, +8801716-752370.
- South Asia Trading. Tel: +8802-9667302, +8802-9667301.
- National World Export & Import (Pvt.) Co. Ltd. Mobile: +8801684-949001.
- Osmonic BD Ltd. Tel: +8802-9571117, +8802-9563079.

Die/Mold Supplier:

- Bangladesh Die & Mold Manufactures Association, 220, New Elephant Road, Dhaka. Tel: +8802-961545415. Mobile: +8801711-526913.

Bibliography:

- Subramanian, M. N., "Compression Molding" in "Handbook of Troubleshooting Plastics Processes: A Practical Guide" (ed J. R. Wagner), John Wiley & Sons Inc., 2012.

- Davis, B., Gramann, P., Rios, A., Osswald, T., “Compression Molding”, Hanser Publications, 2003.
- Meyer, R.W., “Compression Molding Technology” in “Handbook of Polyester Molding Compounds and Molding Technology”, Springer, 1987.

Production Process Flow Chart:

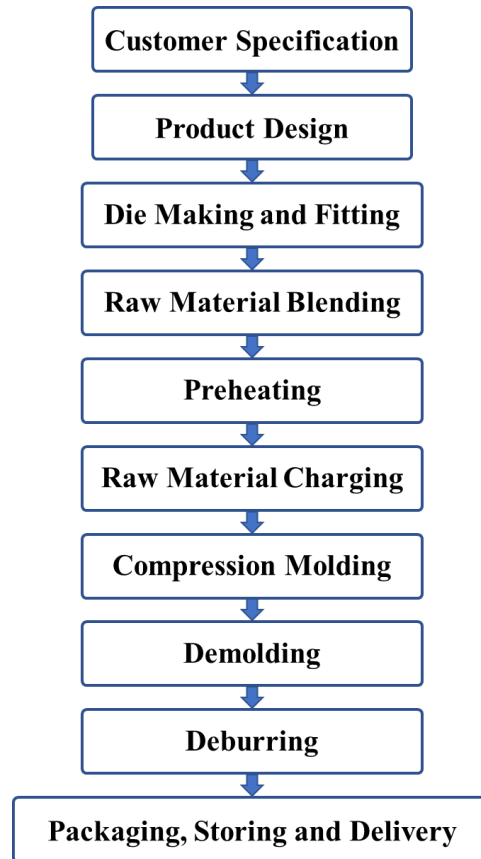

Product-02: Crockery

Sub-sector: Household, Tableware & Kitchenware

HS-2007:	3924.10.00	BSIC-2009:	2220	BCPC-2011:	36940
-----------------	------------	-------------------	------	-------------------	-------

Description:
A Crockery is a type of tableware (i.e. plate, dish, cup, and other related items) used to serve food and beverages made of earthenware, ceramic, plastic or metal.



Raw Materials:

Base Raw Material:	<ul style="list-style-type: none"> • Melamine Formaldehyde (MF) 	<ul style="list-style-type: none"> • Melamine Urea Formaldehyde (MUF)
Additives:	<ul style="list-style-type: none"> • Process Aid and Mold Release 	<ul style="list-style-type: none"> • Pigment

Raw Material Supplier:

- Bangladesh Polymer Importers' Association, 315/B, Tejgaon I/A, Dhaka. Tel: +8802-9830149.
- Bangladesh Chemical Importers and Merchants Association, 124, Hazaribagh, Dhaka-1209. Tel: +8802-8622608, +8802-8624009. Mobile: +8801986-842486.
- Bangladesh Paint Dyes & Chemical Merchants' Association, F.R.Plaza, 18, Imamganj, Dhaka-1100. Mobile: +8801755-651207, +8801711-938123, +8801819-074794.

Machineries and Specification:

1. Compression Molding Machine

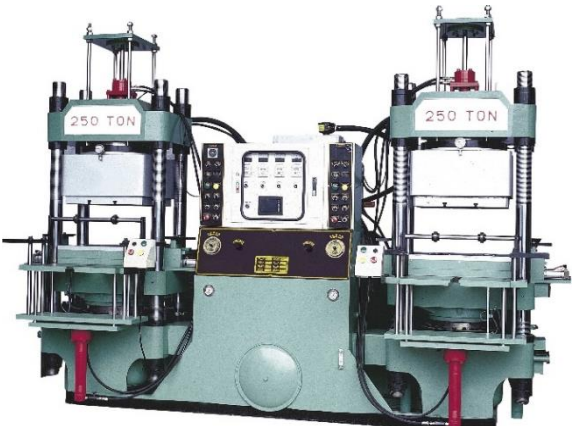
	<ul style="list-style-type: none"> • Clamping Force: ~ 250 ton • Plate Size: ~ 600 x 550 mm • Piston Diameter/ Stroke: ~ 400 mm/ 320 mm • Daylight: ~ 500 mm • System Pressure: ~ 25 MPa • Heating Capacity: ~ 30 kW (15 kW x 2) • Motor Capacity: ~ 15 HP (7.5 HP x2) • Power: ~ 45 kW (400V 3 Phase) • Dimension (LxWxH): ~ 4 x 2 x 3 m • FOB Price: USD 12,000-25,000 • Gross Weight: ~ 15 ton
---	--

2. Compaction/ Briquetting Machine



- Compaction Force: ~ 100 ton
- Compact Thickness: Max. 50 mm
- Compact Dia.: Max. 100 mm
- Output: ~ 5 – 15 pieces/min
- Motor Capacity: ~ 10 HP
- Dimension (LxWxH): ~ 3 x 1.2 x 2 m
- FOB Price: USD 8,000-15,000
- Gross Weight: ~ 0.6 ton

3. High Frequency/ Radio Frequency Preheating Machine



- Power: ~ 10 kW (400V 3 Phase)
- Oscillation Frequency: ~ 50 MHz
- Max. Input Power: ~ 15 kVA
- Electrode Size (LxW): ~ 0.4 x 0.4 m (Flat)
- Chamber Size (LxWxH): ~ 0.5 x 0.8 x 0.2 m
- Dimension (LxWxH): ~ 0.6 x 0.9 x 1.3 m
- FOB Price: USD 3,000-7,000
- Gross Weight: ~ 0.6 ton

4. Belt Grinding Machine



- Belt Size: ~ 2,000 x 150 mm
- Belt Speed: ~ 30 m/sec.
- Contact Disk Dia.: ~ 200 mm
- Table Size: ~ 450 x 150 mm
- Dust Extraction Outlet Dia.: ~ 60 mm
- Motor Capacity: ~ 3 HP
- Power: ~ 3 kW (220V)
- Dimension (LxWxH): ~ 0.6 x 0.5 x 1 m
- FOB Price: USD 400 – 800
- Gross Weight: ~ 0.1 ton

5. Polishing/ Buffing Machine



- Polishing Wheel Media: Fine and Coarse
- Polishing Wheel Dia.: ~ 200 mm
- Polishing Wheel Thickness: ~ 15 mm
- Spindle Dia.: ~ 16 mm
- Motor Capacity: ~ 1 HP
- No Load Speed: ~ 2,800 rpm
- Power: ~ 1 kW (220V)
- Dimension (LxWxH): ~ 0.6 x 0.5 x 0.3 m
- FOB Price: USD 250 – 800
- Gross Weight: ~ 0.1 ton

6. Mixing/ Blending Machine



- Mixing Capacity: 100 kg/hr (250 l)
- Motor Power: ~ 2-4 HP
- Rotating Speed: ~ 90 rpm
- Power: ~ 3 kW (400V 3 Phase)
- Dimension (LxWxH): ~ 1 x 0.8 x 0.85 m
- Optional Feature: Timing Device, Heater
- FOB Price: USD 500-1,500
- Gross Weight: 150-200 kg

Machineries Supplier:

- Bangladesh Hardware & Machinery Merchants' Association (BHMMA), 5, Bangabandu Avenue (3rd Floor), Dhaka. Tel: +8802-9569783. Mobile: +8801924-424085.
- China Bangla Engineers & Consultants Ltd. Mobile: +8801914-867929, +8801716-752370.
- South Asia Trading. Tel: +8802-9667302, +8802-9667301.

Die/Mold Supplier:

- Bangladesh Die & Mold Manufactures Association, 220, New Elephant Road, Dhaka. Tel: +8802-961545415. Mobile: +8801711-526913.

Bibliography:

- Subramanian, M. N., "Compression Molding" in "Handbook of Troubleshooting Plastics Processes: A Practical Guide" (ed J. R. Wagner), John Wiley & Sons Inc., 2012.
- Davis, B., Gramann, P., Rios, A., Osswald, T., "Compression Molding", Hanser Publications, 2003.

Production Process Flow Chart:

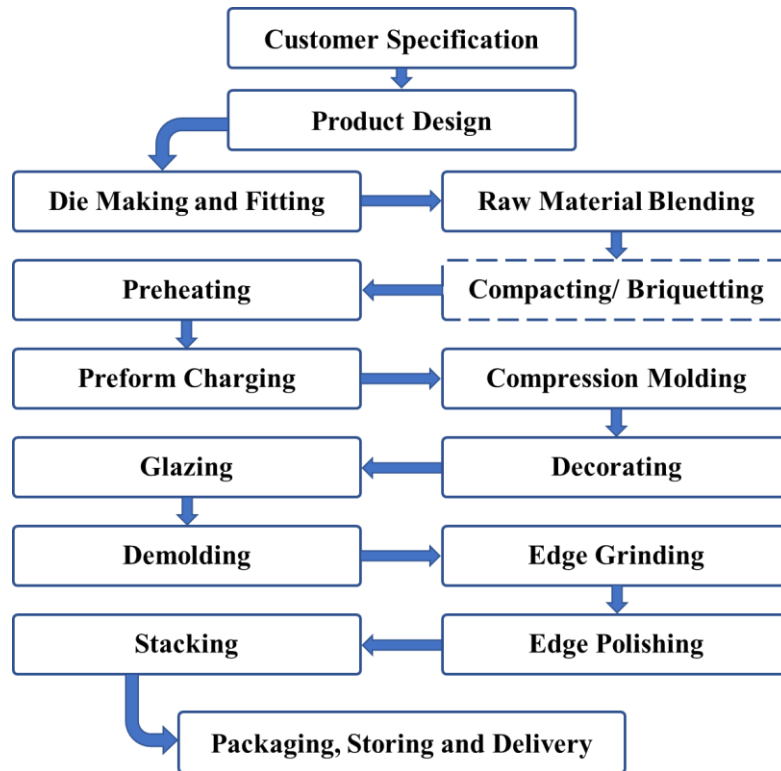

Product-03: Fuse Holder

Sub-sector:	Electrical and Electronic Equipment		
--------------------	-------------------------------------	--	--

HS-2007:	8538.90.00	BSIC-2009:	2710	BCPC-2011:	46220
-----------------	------------	-------------------	------	-------------------	-------

Description:
 A fuse holder is a device that holds a fuse (size depending on device) that is designed to burn out when the power load exceeds the safe limit for the device.



Raw Materials:		
Base Raw Material:	<ul style="list-style-type: none"> Phenol Formaldehyde (FP) 	<ul style="list-style-type: none"> Polyamide Imide (PAI)
Additives:	<ul style="list-style-type: none"> Process Aid and Mold Release 	<ul style="list-style-type: none"> Pigment

Raw Material Supplier:

- Bangladesh Polymer Importers' Association, 315/B, Tejgaon I/A, Dhaka. Tel: +8802-9830149.
- Bangladesh Chemical Importers and Merchants Association, 124, Hazaribagh, Dhaka-1209. Tel: +8802-8622608, +8802-8624009. Mobile: +8801986-842486.
- Bangladesh Paint Dyes & Chemical Merchants' Association, F.R.Plaza, 18, Imamganj, Dhaka-1100. Mobile: +8801755-651207, +8801711-938123, +8801819-074794.

Machineries and Specification:

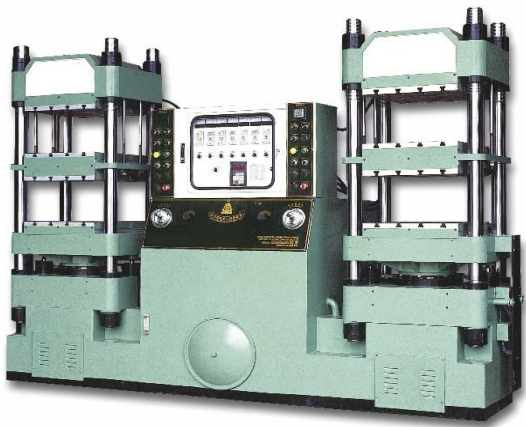
1. Compression Molding Machine	
	<ul style="list-style-type: none"> Clamping Force: ~ 150 ton Plate Size: ~ 600 x 600 mm Piston Diameter: ~ 300 mm Piston Stroke: ~ 550 mm Daylight: ~ 850 mm System Pressure: ~ 20 MPa Heating Capacity: ~ 30 kW (15 x 2) Hydraulic Motor Capacity: ~ 15 HP (7.5 x 2) Power: ~ 45 kW (400V 3 Phase) Dimension (LxWxH): ~ 3.5 x 1.2 x 2.5 m FOB Price: USD 8,000-20,000 Gross Weight: ~ 10 ton

2. High Frequency/ Radio Frequency Preheating Machine



- Power: ~ 8 kW (400V 3 Phase)
- Oscillation Frequency: ~ 50 MHz
- Max. Input Power: ~ 15 kVA
- Electrode Size (LxW): ~ 0.4 x 0.4 m (Flat)
- Chamber Size (LxWxH): ~ 0.5 x 0.8 x 0.2 m
- Dimension (LxWxH): ~ 0.6 x 0.9 x 1.3 m
- FOB Price: USD 4,000-7,000
- Gross Weight: ~ 0.8 ton

3. Vibratory Deburring Machine



- Total Volume: ~ 800 l
- Deburring Media: Polymer Chips
- Deburring Media Capacity: ~ 500 kg
- Bowl Width: ~ 400 mm
- Motor: 5 HP
- Output: Max. 1 ton/hr
- Power: ~ 5 kW
- Dimension (LxWxH): ~ 0.5 x 0.6 x 1.5 m
- FOB Price: USD 3,000-7,000
- Gross Weight: ~ 1 ton

4. Mixing/ Blending Machine



- Mixing Capacity: 100 kg/hr (250 l)
- Motor Power: ~ 2-4 HP
- Rotating Speed: ~ 90 rpm
- Power: ~ 3 kW (400V 3 Phase)
- Dimension (LxWxH): ~ 1 x 0.8 x 0.85 m
- Optional Feature: Timing Device, Heater
- FOB Price: USD 500-1,500
- Gross Weight: 150-200 kg

Machineries Supplier:

- Bangladesh Hardware & Machinery Merchants' Association (BHMMA), 5, Bangabandu Avenue (3rd Floor), Dhaka. Tel: +8802-9569783. Mobile: +8801924-424085.
- South Asia Trading. Tel: +8802-9667302, +8802-9667301.
- China Bangla Engineers & Consultants Ltd. Mobile: +8801914-867929, +8801716-752370.
- National World Export & Import (Pvt.) Co. Ltd. Mobile: +8801684-949001.
- Osmonic BD Ltd. Tel: +8802-9571117, +8802-9563079.

Die/Mold Supplier:

- Bangladesh Die & Mold Manufactures Association, 220, New Elephant Road, Dhaka. Tel: +8802-961545415. Mobile: +8801711-526913.

Bibliography:

- Subramanian, M. N., “Compression Molding” in “Handbook of Troubleshooting Plastics Processes: A Practical Guide” (ed J. R. Wagner), John Wiley & Sons Inc., 2012.
- Davis, B., Gramann, P., Rios, A., Osswald, T., “Compression Molding”, Hanser Publications, 2003.
- Meyer, R.W., “Compression Molding Technology” in “Handbook of Polyester Molding Compounds and Molding Technology”, Springer, 1987.

Production Process Flow Chart:

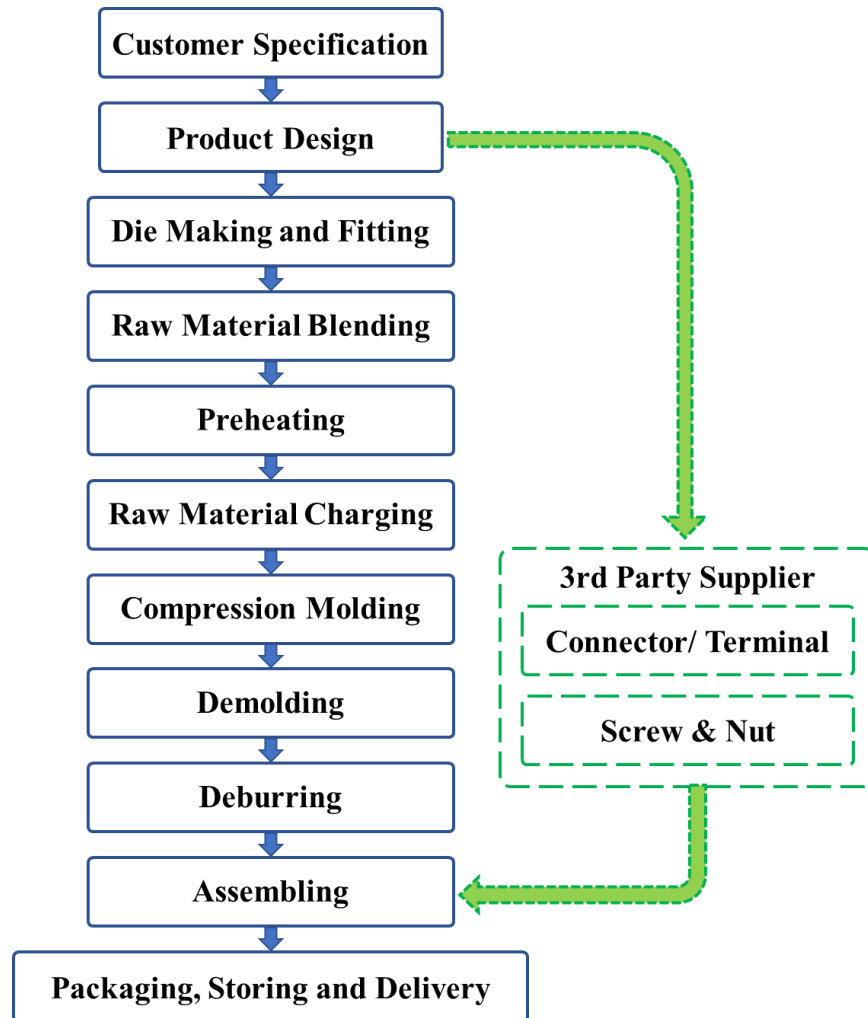

Chapter 7: Miscellaneous Manufacturing Processes

- **Casting Process**

The casting process is a manufacturing process mostly used for metals. In case of plastics, the casting process is the route of manufacturing item through gravity or pressure pouring of liquid resin into a mold cured and hardened in normal room temperature and pressure. Primarily thermosetting resins like phenol formaldehyde, polymethyl methacrylate and polyurethane are used for manufacturing of sheets, rods, tubes; jewelry; radio housings; designer furniture; paperweights, etc.

- **Fabrication Process**

The fabrication process is a unified name in which a variety of operations like bonding, carving, cutting, sticking, turning, milling, blanking, die-cutting, welding, etc. are carried out to manufacture a finished product. This process is mostly applied to cellulose acetate; cellulose nitrate; glass reinforced plastic; phenol formaldehyde, polymethyl methacrylate, polystyrene, etc.

- **Foaming Process**

In the foaming process, a small amount of air or blowing agent is released into the plastic to fill it with bubbles and foam into a desired shape. The materials like polystyrene, polyurethane, polyvinyl chloride, etc. are most widely used to manufacture packaging, sponges, shoes sole, steering wheels, vending cups, insulation, furniture, mattress, etc.

Product-01: Button

Sub-sector: RMG Accessory

HS-2007: 9606.21.00

BSIC-2009: 3290

BCPC-2011: 38923

Description:

A Button is a RMG accessory in the shape of disk or knob sewn onto a garment, either for fastening or for decoration.

Product:



Raw Materials:

Base Raw Material:	<ul style="list-style-type: none"> • Polyester • Silicone Wax
Additives:	<ul style="list-style-type: none"> • Process Aid and Mold Release • Pigment

Raw Material Supplier:

- Bangladesh Polymer Importers' Association, 315/B, Tejgaon I/A, Dhaka. Tel: +8802-9830149.
- Bangladesh Chemical Importers and Merchants Association, 124, Hazaribagh, Dhaka-1209. Tel: +8802-8622608, +8802-8624009. Mobile: +8801986-842486.
- Bangladesh Paint Dyes & Chemical Merchants' Association, F.R.Plaza, 18, Imamganj, Dhaka-1100. Mobile: +8801755-651207, +8801711-938123, +8801819-074794.

Machineries and Specification:

1. Centrifugal Casting Machine



- Drum Size (Dia.xW): ~ 1 x 0.6 m
- Casting Sheet Length: ~ 3 m
- Casting Sheet Thickness: Max. 15 mm
- Rotation Speed: ~ 50 – 200 rpm
- Motor: ~ 2 HP
- Heating Capacity: ~ 3 kW
- Output: ~ 2 – 3 sheets/ hr
- Power: ~ 5 kW (400V 3 Phase)
- Dimension (LxWxH): ~ 2 x 1.5 x 2.5 m
- FOB Price: USD 6,000-15,000
- Gross Weight: ~ 1 ton

2. Blanking Machine



- Sheet Length: ~ 0.2 – 2.5 m
- Sheet Width: ~ 0.5 – 1 m
- Sheet Thickness: ~ 5 – 15 mm
- Stroke Rate: ~ 150 nos./ min
- Output: Max. 2,500 pieces/hr
- Air Consumption: ~ 0.25 cu. m/hr
- Power: ~ 5 kW (400V 3 Phase)
- Dimension (LxWxH): ~ 2.5 x 1.5 x 1.8 m
- FOB Price: USD 5,000-15,000
- Gross Weight: ~ 1.5 ton

3. Forming Machine







- Blank Thickness: Max. 15 mm
- Forming Chuck: ~ 2
- Forming Stations: 4 nos./ Chuck
- Turning Depth: 1 – 5 mm
- Drilling Depth: 1 – 7 mm
- Drill Hole Dia.: Max. 5 mm
- Laser Engraving Area: ~ 50 x 50 mm
- Laser Engraving Speed: Max. 6,000 mm/sec
- Output: 5 – 400 buttons/min
- Power: ~ 12 kW (400V 3 Phase)
- Dimension (LxWxH): ~ 2 x 1.5 x 2 m
- FOB Price: USD 12,000-20,000
- Gross Weight: ~ 0.8 ton

4. Polishing & Waxing Machine



- Drum Capacity: Max. 400 l
- Drum Inner Lining: Polyurethane
- Rotation Speed: Max. 50 rpm
- Spray System: Water and Wax (Separate)
- Water Input Pressure: ~ 0.1 – 0.5 MPa
- Wax Dispenser Capacity: Max. 0.5 l/min
- Polishing Media: Ceramic Chips
- Power: ~ 60 kW (400V 3 Phase)
- Dimension (LxWxH): ~ 1.5 x 2 x 2.5 m
- FOB Price: USD 8,000-15,000
- Gross Weight: ~ 1 ton

5. Unloading Unit	
	<ul style="list-style-type: none"> • Unloading Media: Stainless Steel Strainer • Unloading Time: 2 – 3 min • Unloading Capacity: Max. 50 kg/batch • Pump Output: Max. 50 l/min • Power: ~ 2 kW (220V) • Dimension (LxWxH): ~ 1 x 1 x 1.5 m • FOB Price: USD 1,000-2,500 • Gross Weight: 150-200 kg
6. Dyeing Machine	
	<ul style="list-style-type: none"> • Tank Capacity: 50 l • Heating Capacity: ~ 5 kW • Mixing Type: Stirring • Container: Stainless Steel Basket • Strainer: Vibratory • Power: ~ 6 kW (400V 3 Phase) • Dimension (LxWxH): ~ 0.5 x 1 x 1.5 m • Optional Feature: Timer, Alarm, Transducer • FOB Price: USD 1,500-3,500 • Gross Weight: 100-150 kg
7. Centrifugal Drying Machine	
	<ul style="list-style-type: none"> • Container: Stainless Steel Basket • Basket Size (Dia.xH): ~ 450 x 350 mm • Basket Capacity: ~ 50 kg (60 l) /batch • Motor: 2 HP • Rotation: ~ 700 rpm • Heating Capacity: ~ 3 kW • Power: ~ 6 kW (400V 3 Phase) • Dimension (LxWxH): ~ 1 x 0.7 x 1.2 m • FOB Price: USD 2,500-4,500 • Gross Weight: 150-180 kg
8. Size Separation Machine	
	<ul style="list-style-type: none"> • Separation System: Sieve • No. of Sieve: 3 • Sieve Hole Dia.: ~ 8, 12, 16, 22 mm • Sieve Type: Interchangeable • Motor: 0.5 HP • Power: ~ 0.5 kW (220V) • Dimension (LxWxH): ~ 0.7 x 1 x 1.5 m • FOB Price: USD 2,000-3,500 • Gross Weight: 200-250 kg

9. Thickness Separation Machine



- Separation System: Cylinder Rolling
- Cylinder Size (Dia.xL): ~ 120 x 1,500 mm
- Cylinder Rotation: ~ 120 rpm
- Collection Box: 6 nos.
- Separable Thickness: 1 – 15 mm
- Motor: 0.5 HP
- Power: ~ 0.5 kW (220V)
- Dimension (LxWxH): ~ 1.5 x 0.8 x 1.5 m
- FOB Price: USD 3,000-5,000
- Gross Weight: 300-400 kg

10. Inspection Separation Machine



- Hopper Capacity: ~ 5 kg (8 l)
- Belt Size (LxWxT): ~ 3,000 x 200 x 3 mm
- Output: ~ 1,000 – 3,000 pieces/hr
- Motor: 0.3 HP
- Power: ~ 0.3 kW (220V)
- Dimension (LxWxH): ~ 2 x 0.6 x 1.2 m
- FOB Price: USD 800-1,500
- Gross Weight: 150-250 kg

11. Resin Stirring Machine



- Motor: 0.5 HP
- Rotation: Max. 1,200 rpm
- Container Capacity: Max. 20 kg
- Power: ~ 0.5 kW (220V)
- Dimension (LxWxH): ~ 0.5 x 0.6 x 1.2 m
- FOB Price: USD 500-1,000
- Gross Weight: 100-150 kg

Machineries Supplier:

- Bangladesh Hardware & Machinery Merchants' Association (BHMMA), 5, Bangabandu Avenue (3rd Floor), Dhaka. Tel: +8802-9569783. Mobile: +8801924-424085.
- China Bangla Engineers & Consultants Ltd. Mobile: +8801914-867929, +8801716-752370.

Die/Mold Supplier:

- Bangladesh Die & Mold Manufactures Association, 220, New Elephant Road, Dhaka. Tel: +8802-961545415. Mobile: +8801711-526913.

Bibliography:

- Throne, James L., "Plastics Process Engineering", Marcel Dekker, 1979.
- Michaeli, Walter, "Plastics Processing: An Introduction", Hanser Gardner Publications, 1995.
- Wolf, Rory A., "Plastic Surface Modification: Surface Treatment and Adhesion", Hanser Gardner Publications, 2016.

Production Process Flow Chart:

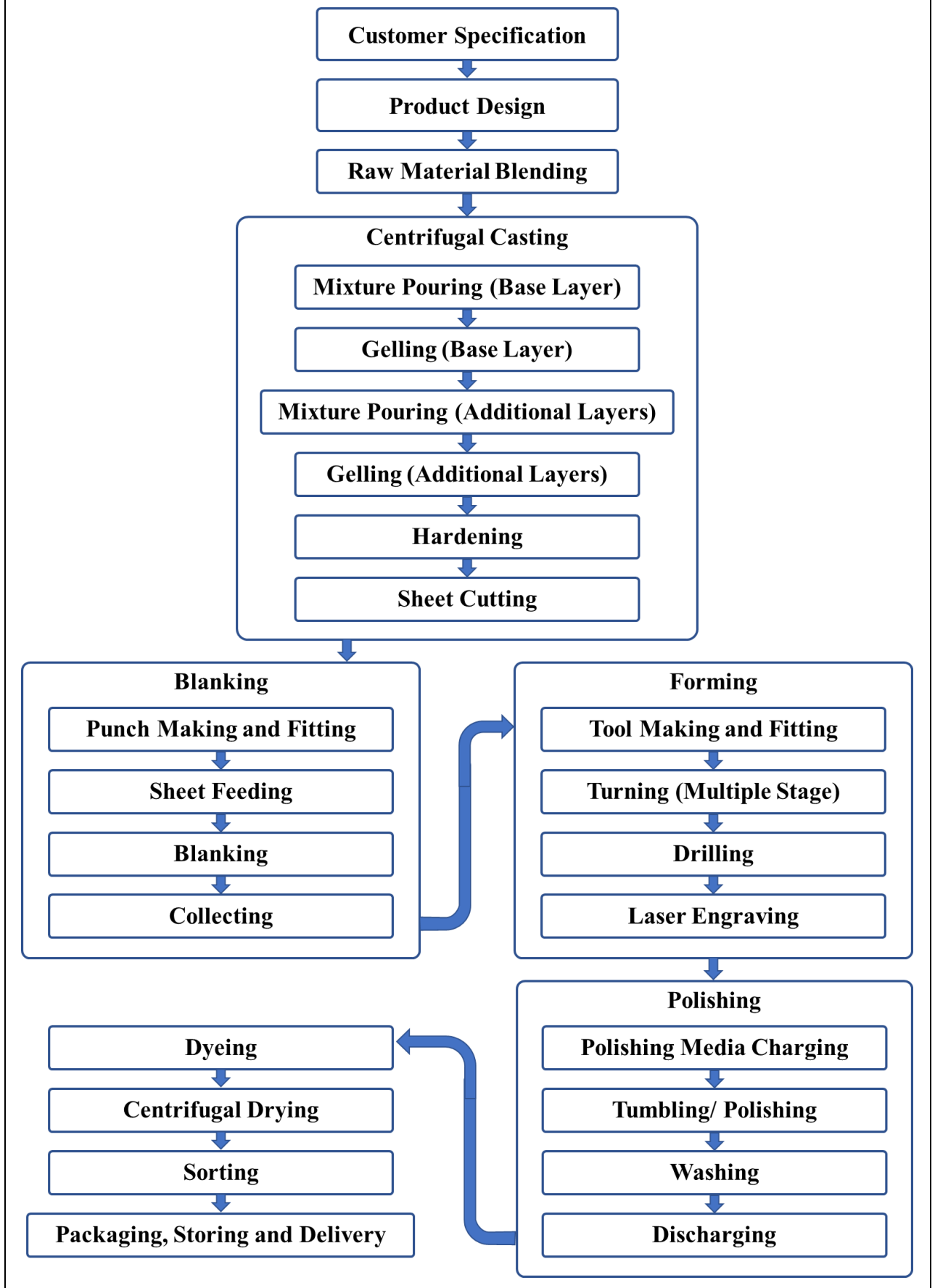

Product-02: Spectacle Frame

Sub-sector: Healthcare

HS-2007: 9003.11.00

BSIC-2009: 3250

BCPC-2011: 48313

Description:

A Spectacle or Goggle Frame is a structure to enclose or support ophthalmic lenses used for vision correction, eye protection or simply for aesthetic purposes.

Product:



Raw Materials:

Base Raw Material:	<ul style="list-style-type: none"> Cellulose -Acetate Sheet
Additives:	<ul style="list-style-type: none"> Process Aid and Mold Release Pigment

Raw Material Supplier:

- Bangladesh Polymer Importers' Association, 315/B, Tejgaon I/A, Dhaka. Tel: +8802-9830149.
- Bangladesh Chemical Importers and Merchants Association, 124, Hazaribagh, Dhaka-1209. Tel: +8802-8622608, +8802-8624009. Mobile: +8801986-842486.
- Bangladesh Paint Dyes & Chemical Merchants' Association, F.R.Plaza, 18, Imamganj, Dhaka-1100. Mobile: +8801755-651207, +8801711-938123, +8801819-074794.

Machineries and Specification:

1. Blanking Press



- Sheet Length: ~ 0.2 – 2.5 m
- Sheet Width: ~ 0.5 – 1 m
- Sheet Thickness: ~ 5 – 15 mm
- Force: ~ 1,500 kN
- Stroke Rate: ~ 150 nos./ min
- Cutting Speed: Max. 100 mm/sec
- Power: ~ 20 kW (400V 3 Phase)
- Dimension (LxWxH): ~ 2 x 2.5 x 3 m
- FOB Price: USD 15,000-25,000
- Gross Weight: ~ 5 ton

2. CNC 5 Axis Machining Center



- X/Y/Z Travel: Max. 500/ 300/ 200mm
- D/S Rotation: Max. 360°/90°
- Milling Spindles: 12 nos.
- Spindle Speed: ~ 5,000 – 40,000 rpm
- Collet Size: ~ 0.5 – 7.0 mm
- Fast Motion: ~ 60 m/min
- Path Speed: ~ 15 m/min
- Compressed Air: ~ 0.5 MPa, 300 l/min
- Power: ~ 5 kW (400V 3 Phase)
- Dimension (LxWxH): ~ 2.2 x 1.2 x 2.1 m
- FOB Price: USD 30,000-50,000
- Gross Weight: ~ 2 ton

3. Frame Front Bending Machine



- No. of Station: 1 nos.
- Platen Size(LxW): Max. 220 x 150 mm
- Stroke: Max. 150 mm
- Output: ~ 1,200 pieces/hr
- Compressed Air: ~ 0.5 MPa, 150 l/min
- Heating Capacity: ~ 0.3 kW
- Operating Pressure: ~ 0.5 MPa
- Power: ~ 0.8 kW (220V)
- Dimension (LxWxH): ~ 0.8 x 0.8 x 1.5 m
- FOB Price: USD 4,000-8,000
- Gross Weight: ~ 0.4 ton

4. High Frequency Heating Machine



- Working Area (LxWxH): ~ 0.3 x 0.2 x 0.2 m
- Electrode Size (LxW): ~ 0.3 x 0.2 m (Flat)
- Oscillation Frequency: ~ 50 MHz
- Operating Pressure: ~ 0.6 MPa
- Power: ~ 3 kW (400V 3 Phase)
- Dimension (LxWxH): ~ 0.5 x 0.4 x 1.3 m
- FOB Price: USD 2,500-5,000
- Gross Weight: ~ 120 kg

5. Temple Tip Bending Machine



- No. of Station: 1 nos.
- Rotation: Max. 80°
- No. of Rotation Axis: 2 nos.
- Output: ~ 1,500 pieces/hr
- Compressed Air: ~ 0.5 MPa, 150 l/min
- Power: ~ 0.2 kW (220V)
- Dimension (LxWxH): ~ 0.7 x 0.4 x 0.5 m
- FOB Price: USD 2,500-4,000
- Gross Weight: 50-80 kg

6. Temple Tip Heating Machine



- No. of Station: 2 nos.
- Area/ Station (Dia.x H): ~ 300 x 150 mm
- Heating Element: Quartz
- Heating Capacity: ~ 0.5 kW/Station
- Compressed Air: ~ 0.5 MPa, 150 l/min
- Power: ~ 1.2 kW (400V 3 Phase)
- Dimension (LxWxH): ~ 0.6 x 0.4 x 0.8 m
- FOB Price: USD 1,500-3,000
- Gross Weight: ~ 20 kg

7. Polishing Machine



- Drum Capacity: Max. 100 l
- Drum Inner Lining: Polyurethane
- Rotation Speed: Max. 150 rpm
- Spray System: Water and Wax (Separate)
- Water Input Pressure: ~ 0.1 – 0.5 MPa
- Wax Dispenser Capacity: Max. 0.5 l/min
- Polishing Media: Ceramic Chips
- Power: ~ 10 kW (400V 3 Phase)
- Dimension (LxWxH): ~ 2 x 2 x 2.5 m
- FOB Price: USD 8,000-12,000
- Gross Weight: ~ 1 ton

8. Hydrodynamic Separation Machine



- Separation Type: Stainless Steel Strainer
- Cycle Time: 3 min
- Batch Size: ~ 50 kg
- Pump Output: Max. 50 l/min
- Chamber Size (LxWxH): ~ 0.6 x 1.5 x 1.8 m
- Power: ~ 1.5 kW (220V)
- Dimension (LxWxH): ~ 1.5 x 0.8 x 1.5 m
- FOB Price: USD 500-1,500
- Gross Weight: ~ 200 kg

9. Ultrasonic Welding Machine



- Working Area (LxWxH): ~ 0.6 x 0.3 x 0.2 m
- Electrode Dia.: ~ 20 mm (Round)
- Oscillation Frequency: ~ 20 kHz
- Weld & Hold Time Range: ~ 0.1 – 1 sec
- Stroke: ~ Max. 100 mm
- Power: ~ 2.5 kW (220V)
- Dimension (LxWxH): ~ 0.7 x 0.4 x 1 m
- FOB Price: USD 2,500-5,000
- Gross Weight: ~ 50 kg

10. Automatic Screwdriver Machine



- Hopper Capacity: ~ 2 kg
- Stroke: Max. 100 mm
- Rotation Speed: ~ 2,000 rpm
- Screw Size (Dia.xL): Min. 1.5 x 3 mm
- Output: Max. 2 screw/sec
- Compressed Air: ~ 0.7 MPa, 15 l/min
- Power: ~ 0.3 kW (220V)
- Dimension (LxWxH): ~ 2 x 0.4 x 1.5 m
- FOB Price: USD 1,000-2,500
- Gross Weight: ~ 50 kg

11. Pad Printing Machine



- Printing Force: Max. 800 N
- No. of Color: 1 or 2
- Printing Speed: Max. 1,800 cycles/hr
- Vertical Stroke: ~ 100 mm
- Pad Height: Max. 90 mm
- Ink Cup Capacity: 250 ml
- Power: ~ 1.5 kW (220V)
- Dimension (LxWxH): ~ 0.5 x 0.6 x 1.2 m
- FOB Price: USD 1,500-3,000
- Gross Weight: ~ 50 kg

12. Ultrasonic Cleaning Machine



- Stages: 3 (Cleaning, Rinsing, Washing)
- No. of Tank: Clean (2), Rinse (1), Wash (1)
- Each Tank Size (LxWxH): 0.2 x 0.3 x 0.3 m
- Ultrasonic Frequency: 28 kHz/ 40 kHz
- No. of Transducer: 12
- Ultrasonic Output: Max. 600 W
- Heating Capacity: Max. 1.5 kW
- Power: ~ 2.5 kW (400V 3 Phase)
- Dimension (LxWxH): ~ 2.5 x 0.8 x 0.9 m
- FOB Price: USD 4,500-8,000
- Gross Weight: ~ 250 kg

13. Centrifugal Drying Machine



- Basket Capacity: Max. 50 Frames
- Drying Cycle; 3 – 5 min
- Rotation: ~ 500 rpm
- Heating Capacity: ~ 5 kW
- Power: ~ 6 kW (400V 3 Phase)
- Dimension (LxWxH): ~ 1.6 x 1 x 1 m
- FOB Price: USD 4,500-8,000
- Gross Weight: ~ 250 kg

Machineries Supplier:

- Bangladesh Hardware & Machinery Merchants' Association (BHMMA), 5, Bangabandu Avenue (3rd Floor), Dhaka. Tel: +8802-9569783. Mobile: +8801924-424085.
- China Bangla Engineers & Consultants Ltd. Mobile: +8801914-867929, +8801716-752370.
- South Asia Trading. Tel: +8802-9667302, +8802-9667301.
- Kulsum Enterprise. Mobile: +8801913-544816.
- National World Export & Import (Pvt.) Co. Ltd. Mobile: +8801684-949001.
- Osmonic BD Ltd. Tel: +8802-9571117, +8802-9563079.

Die/Mold Supplier:

- Bangladesh Die & Mold Manufactures Association, 220, New Elephant Road, Dhaka. Tel: +8802-961545415. Mobile: +8801711-526913.

Bibliography:

- Throne, James L., "Plastics Process Engineering", Marcel Dekker, 1979.
- Michaeli, Walter, "Plastics Processing: An Introduction", Hanser Gardner Publications, 1995.
- Wolf, Rory A., "Plastic Surface Modification: Surface Treatment and Adhesion", Hanser Gardner Publications, 2016.

Production Process Flow Chart:

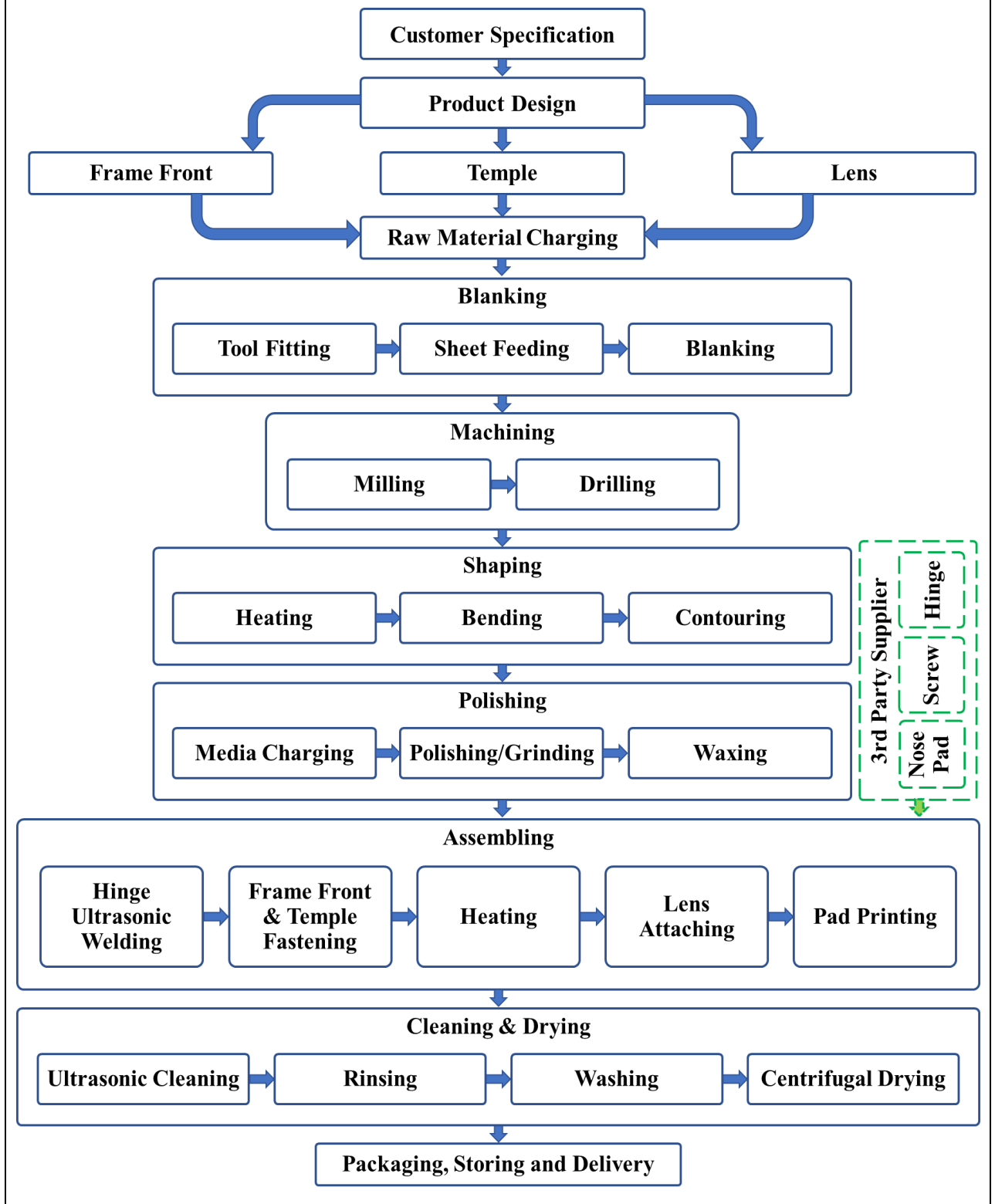

Product-03: Smart Card

Sub-sector:	Electrical and Electronic Equipment				
HS-2007:	8523.52.00	BSIC-2009:	2610	BCPC-2011:	47920

Description:
A Smart Card is any pocket-sized card made of plastic that has embedded integrated circuits to provide personal identification, authentication, data storage, and application processing.



Raw Materials:

Base Raw Material:	<ul style="list-style-type: none"> • Polymer Sheet (ABS, PETg, PP, PVC) Sheet • Magnetic Tape, Micro-processor Chip
Additives:	<ul style="list-style-type: none"> • Process Aid and Mold Release • Pigment

Raw Material Supplier:

- Bangladesh Polymer Importers' Association, 315/B, Tejgaon I/A, Dhaka. Tel: +8802-9830149.
- Bangladesh Chemical Importers and Merchants Association, 124, Hazaribagh, Dhaka-1209. Tel: +8802-8622608, +8802-8624009. Mobile: +8801986-842486.
- Bangladesh Paint Dyes & Chemical Merchants' Association, F.R.Plaza, 18, Imamganj, Dhaka-1100. Mobile: +8801755-651207, +8801711-938123, +8801819-074794.

Machineries and Specification:

1. Magnetic Tape Laying Machine

	<ul style="list-style-type: none"> • Overlay Type: Sheet or Roll • Overlay Thickness: ~ 0.05 – 0.2 mm • Overlay Width: ~ 250 – 700 mm • Tape Tracks: 8 – 10 nos. • Positioning & Cutting Accuracy: ± 0.15 mm • Pressure/ Temperature: 30 – 55 N / 200°C • Operation Speed: ~ 5 – 10 m/min • Power: ~ 5 kW (400V 3 Phase) • Dimension (LxWxH): ~ 2.5 x 1.8 x 2 m • FOB Price: USD 10,000-15,000 • Gross Weight: ~ 2.5 ton
--	---

2. Sheet Collating Machine



- Operations: Gathering, Adjusting, Welding and Cutting
- Sheet Size (LxW): ~ 750 x 750 mm
- Overlay Thickness: 0.04 – 0.4 mm
- Welding Type: Ultrasonic
- Positioning & Cutting Accuracy: ± 0.2 mm
- Collating Thickness: Max. 1 mm
- Output: ~ 1,000 sheets/hr
- Power: ~ 12 kW (400V 3 Phase)
- Dimension (LxWxH): ~ 5 x 2 x 2.5 m
- FOB Price: USD 15,000-30,000
- Gross Weight: ~ 4 ton

3. Sheet Laminating Machine



- Openings: 4 – 8 nos.
- Sheet Size (LxW): ~ 750 x 750 mm
- Sheet Thickness; Max. 1 mm
- Lamination Force: 50 – 1,250 kN
- Lamination Temperature: Max. 250°C
- Surface Finish: ≤ 1.2 μ m
- Output: ~ 1,200 sheets/hr
- Power: ~ 15 kW (400V 3 Phase)
- Dimension (LxWxH): ~ 5 x 2.5 x 2.5 m
- FOB Price: USD 25,000-50,000
- Gross Weight: ~ 5 ton

4. Card Punching Machine



- Punching Tools: Max. 5 nos.
- Sheet Size (LxW): ~ 750 x 750 mm
- Sheet Thickness; Max. 1 mm
- Punching Force: 100 kN
- Punching Speed: 25 – 200 mm/sec
- Punching Accuracy: ± 0.1 mm
- Output: ~ 35,000 cards/hr
- Power: ~ 20 kW (400V 3 Phase)
- Dimension (LxWxH): ~ 3.5 x 2 x 2.5 m
- FOB Price: USD 20,000-40,000
- Gross Weight: ~ 5 ton

5. Card Inspection Machine



- Card Size/ Thickness: ID1/ 0.3 – 1 mm
- Print Inspection Camera: Color Matrix
- Print Inspection Resolution: 75 μm / pixel
- Surface Inspection Camera: Grayscale Matrix
- Surface Inspection Resolution: 75 μm / pixel
- Other Inspection: UV, Microtext/ DOVID
- Output: 35,000 Cards/hr
- Power: ~ 8 kW (400V 3 Phase)
- Dimension (LxWxH): ~ 3.5 x 2 x 2.5 m
- FOB Price: USD 10,000-25,000
- Gross Weight: ~ 2.5 ton

6. Card Hot Stamping Machine



- Foil Width: 10 – 85 mm
- Foil Outer Dia.: 200 mm
- Hologram Positioning: Adjustable Pitch
- Stamping Pressure: Manually adjustable
- Stamping Temperature: Max. 230°C
- Output: 6,000 Cards/hr
- Power: ~ 5 kW (400V 3 Phase)
- Dimension (LxWxH): ~ 0.7 x 0.4 x 0.5 m
- FOB Price: USD 3,000-8,000
- Gross Weight: ~ 1.5 ton

7. Milling and Implanting Machine



- IC Modules: 35 mm tapes; 9.5/14.5 mm pitch
- Card Type: ID1/ PC, ABS, PET, PETG
- CNC Milling Head: 2 nos. (3 axis each)
- Dynamic Drive Accuracy (x,y,z): $\pm 0.10 \mu\text{m}$
- Measurement Accuracy: $\pm 2.5 \mu\text{m}$
- Implanting Accuracy: $\pm 30 \mu\text{m}$
- Implanting Pressure: Max. 200 N
- Implanting Temperature: Max. 300°C
- Output: 6,000 Cards/hr
- Power: ~ 10 kW (400V 3 Phase)
- Dimension (LxWxH): ~ 3 x 2 x 2.5 m
- FOB Price: USD 18,000-30,000
- Gross Weight: ~ 3 ton

8. Card Personalization Machine



- Operations: Printing, Embossing, Encoding
- Card Type: ID1/ PC, ABS, PET, PETG
- Printing: Inkjet/ Sublimation/ UV
- Embossing/ Indenting: 150 characters
- Tipping: Color/ Monochrome
- Magnetic Encoding: ISO 7811, HiCo, LoCo
- Contactless Encoding: ISO 14443/ 15693
- Contact Encoding: ISO ISO 7816
- Output: 1,500 Cards/hr
- Power: ~ 5 kW (400V 3 Phase)
- Dimension (LxWxH): ~ 2 x 1.5 x 1.8 m
- FOB Price: USD 10,000-15,000
- Gross Weight: ~ 1 ton

9. Card Counting Machine



- Card Type: ID1/ PC, ABS, PET, PETG
- Card Box Length: Max. 450 mm
- Camera: High Res. Line Scan
- Process: Contactless Digital Image Analysis
- Light Source: LED Bar
- Counting Speed: ~ 500 Cards/sec
- Power: ~ 150 W (220V)
- Dimension (LxWxH): ~ 0.6 x 0.5 x 0.5 m
- FOB Price: USD 500-1,500
- Gross Weight: ~ 50 kg

Machineries Supplier:

- Bangladesh Hardware & Machinery Merchants' Association (BHMMA), 5, Bangabandu Avenue (3rd Floor), Dhaka. Tel: +8802-9569783. Mobile: +8801924-424085.
- China Bangla Engineers & Consultants Ltd. Mobile: +8801914-867929, +8801716-752370.
- South Asia Trading. Tel: +8802-9667302, +8802-9667301.
- Kulsum Enterprise. Mobile: +8801913-544816.
- National World Export & Import (Pvt.) Co. Ltd. Mobile: +8801684-949001.
- Osmonic BD Ltd. Tel: +8802-9571117, +8802-9563079.

Die/Mold Supplier:

- Bangladesh Die & Mold Manufactures Association, 220, New Elephant Road, Dhaka. Tel: +8802-961545415. Mobile: +8801711-526913.

Bibliography:

- Throne, James L., "Plastics Process Engineering", Marcel Dekker, 1979.
- Michaeli, Walter, "Plastics Processing: An Introduction", Hanser Gardner Publications, 1995.
- Wolf, Rory A., "Plastic Surface Modification: Surface Treatment and Adhesion", Hanser Gardner Publications, 2016.

Production Process Flow Chart:

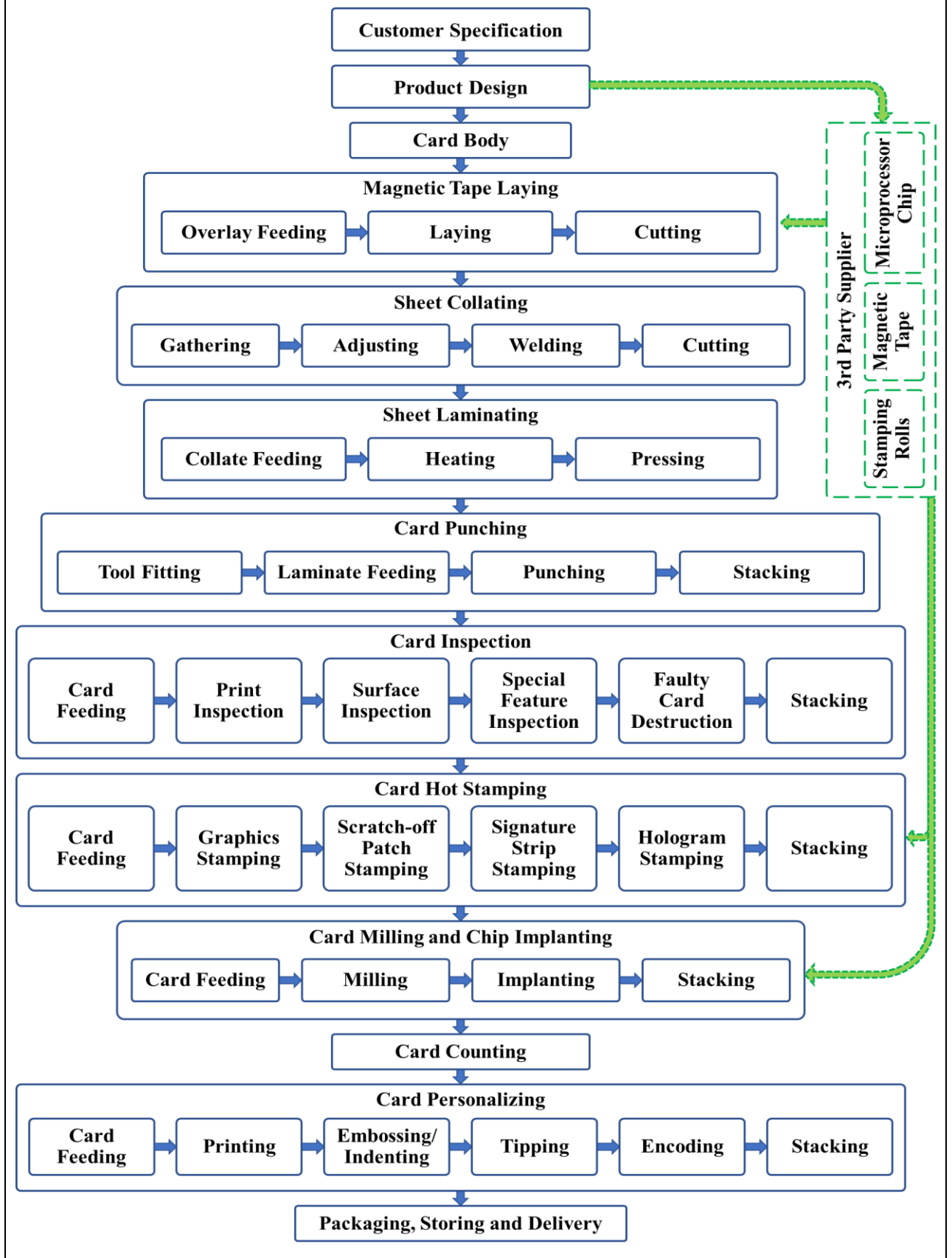

Annex-1: List of Products under Mandatory Certification Marks Scheme

A. Food and Agricultural Products (64 items):

Sl.	Name of the products	Standard No.
1.	Fruit Juice & Nectars	BDS CAC 247:2008
2.	Ice Cream	BDS 1083 :2006
3.	Concentrated Fruit Juice	BDS 527:2007
4.	Chilies, Whole and Ground	BDS 1017:2001
5.	Fruit Squash	BDS 506:2002
6.	Soya bean Oil	BDS 909:2000
7.	Jam, (Fruit Preserves) & Jelly's	BDS CAC 79:2008
8.	Mustard Oil	BDS 25:2000, Amend: 3, 2007
9.	Citrus Mamalade	BDS CAC 80: 2008
10.	Turmeric Powder	BDS 991: 2001
11.	Vinegar	BDS CAC 162:2007
12.	Edible Palm Oil	BDS 999:2000
13.	Fruit Syrup	BDS 528:2006
14.	Sugar	BDS CAC 212:2006
15.	Honey	BDS CAC 12:2007
16.	Suji (Semolina)	BDS 190:1991, Amend 1: 2001
17.	Canned & Bottled Fruit	BDS 503:2006
18.	Pasteurized Milk	BDS 1702:2002
19.	Fruit Cordial	BDS 508:2006
20.	Chips/Crackers	BDS 1556:1997, Amend 1: 2004
21.	Sauce (Fruits or Vegetable)	BDS 512:2007
22.	Chanachur	BDS 1564:1997, Amend 1: 2004
23.	Tomato Paste	BDS 517:2002
24.	Lachha Semai	BDS 1620:2000
25.	Pickles	BDS 520:2001
26.	Soft Drink Powder	BDS 1586:2007
27.	Canned Pineapple	BDS CAC 42:2007
28.	Banaspati	BDS 804:2001
29.	Tomato Ketchup	BDS 530:2002
30.	Instant Noodles	BDS 1552:2007
31.	Infant Formula & Formulas for Special Medical purposes intended for infants	BDS CAC-72-2008
32.	Processed cereal based food for infants & Young Children	BDS CAC 74 :2007
33.	Milk Fat Products	BDS CAC A:2:2008
34.	Edible Sun Flower Oil	BDS CAC 23: 2002
35.	Butter	BDS CAC-A-1:2002
36.	Mosquito Coil	BDS 1089: 2007
37.	Milk Powder and Cream Powders	BDS CAC 207:2008
38.	Malathion 57% (W/V) (Emulsifiable Concentrates)	BDS 1179: 2001
39.	White Bread	BDS 382:2001
40.	Plywood for General Purposes	BDS 799: 2006
41.	Biscuit	BDS 383:2001
42.	Plywood Tea-Chest	BDS 18:2006
43.	Lozenges	BDS 490:2001, Amend 1: 2007
44.	Safety matches in boxes	BDS 1040:2006
45.	Toffees	BDS 1000:2001
46.	Wheat Bran	BDS 997:2006
47.	Black Tea Definition & Basic requirements	BDS ISO:3720:2008

48.	Condensed Milk and Condensed Skim Milk	BDS CAC A-4:2002
49.	Liquid Glucose (Glucose Syrup)	BDS CAC 9:2006
50.	Refined Palm Olein	BDS 1567:2007
51.	Dextrose Monohydrate	BDS CAC 8:2007
52.	Yoghurt and Sweetened Yoghurt	CAC-A-11(a):2002
53.	Maida	BDS 381:2007
54.	Curry Powder	BDS 1205: 2006
55.	Wheat Atta	BDS 380:1980, Amend 1: 2001
56.	Fortified Soybean Oil	BDS 1769:2006, Amend 1: 2008
57.	Carbonated Beverages	BDS 1123:2002, Amend 1: 2007
58.	Fortified Edible Palm Oil	BDS 1770:2006, Amend 1:2008
59.	Noodles	BDS 1106:2001
60.	Refined Sugar	138: 2006
61.	Iodized Salt	BDS 1236:2001, Amend 1: 2007
62.	Cake	BDS 1574: 2006
63.	Drinking Water	BDS 1240:2001
64.	Natural Mineral Water	BDS 1414:2000

B. Chemical Products (40 items):

Sl.	Name of the products	Standards No.
65.	Coconut Oil	BDS 99:2007
66.	Carbolic Soap	BDS 181:02Amend1:02
67.	Stencil Paper	BDS 1030:98 Amend 1: 06
68..	Ink, Duplicating	BDS 146:2002
69.	Writing and Printing Papers	BDS 405:96 Amen1:06
70.	Ferro-gallo tannate Fountain Pen Ink	BDS 88:91Amend 1:06
71.	Pencils	BDS 330:93 Amen 1:06
72.	Ceramic Tableware	BDS 485:2000 Amend 1,2,3 :06
73.	Ready Mixed Paint, brushing, finishing semi gloss for general purpose.	BDS 402:1989 Amend 1 ,2: 2007,
74.	Tableware Made of Melamine Plastics	BDS 1425 :2009
75.	Shoe Polish, Paste	BDS 1006:1981 Amend 1: 06
76.	Skin Cream	BDS 1382:1992Amend 1,2,3: 06
77.	Coal Tar Black Paint (Alquatra)	BDS 69 Part-2):91 Amend 1 : 06
78.	Shaving Cream	BDS 1241:1989 Amend 1,2 : 06
79.	Toilet Soap	BDS 13:06 Amend 1:08
80.	After Shave Lotion	BDS 1524:2006
81.	Laundry Soap Powder	BDS 329: 2006
82.	Lipstick	BDS 1424:1993 Amend 1,2 : 06
83.	Laundry Soap	BDS 12:2006
84.	Hair Oils	BDS BDS 1339:91Amend:1 :06
85.	Ink Stamp Pad	BDS 90:2002
86.	Shampoo, Synthetic Deter-gent based	BDS 1269:02 Amend 1: 03
87.	News Print	BDS 845:94 Amend 1:06
88.	Ammonium Sulfate (Fertilizer)	BDS 36:93 Amend 1:08
89.	Urea (Fertilizer)	BDS 217:1993
90.	Ball Point Pens	BDS 1384:2002
91.	Aluminium Sulphate, Non Ferric	BDS 149:1990
92.	High Speed Diesel	BDS 344:1991 Amendment 1:2000,2:03
93.	Triple Super Phosphate (T.S.P.)	BDS 216:1991 Amend 1 ,2 : 07,
94.	Unleaded Motor Gasoline-Premium	BDS 346:99Amend1:03
95.	Ribbons, Type writer	BDS 236: 2006
96.	Unleaded Motor Gasoline-Regular	BDS 347:1999 Amend 1 : 06

97.	Water Resistant Vegetable Tanned Sole Leather	BDS 340:1991
98.	Tooth Powder	BDS 1370:1992 Amend 1 : 06
99.	Carbon Paper for type writer	BDS 411:89Amend1:06
100.	Skin Powder	BDS 1337:1991Amend 1 :06
101.	Tooth Paste	BDS 1216:2001 Amend 1,2,3 : 06
102.	Cement Paints	BDS 1706:2002
103.	Synthetic Detergent Powder	BDS 1445:2003
104.	Tableware urea molding compound	BDS 1825:2011

C. Jute and Textile Products (11 items):

Sl.	Name of the products	Standards No.
105.	Rubber conveyor and elevator belting of ply construction.	BDS 1200(Part 1:2005
106.	Polyester Cotton Shirting	BDS 1148:2003
107.	Cotton Sewing Thread	BDS 33:1989
108.	Polyester blend Suiting	BDS 1175:2002
109.	Industrial Sewing Thread made wholly or partly from synthetic fibre	BDS 1221:2001
110.	Rubber Flat Transmission Belting of Textile	BDS 1199:2006
111.	Umbrella cloth	BDS 1125:2005
112.	Poplin Fabric	BDS 32:2001
113.	Textiles Color Fastness Ratings Specification	BDS 1758:2006
114.	Cotton Canvas	BDS 319:2005
115.	Fastness of Dyes on Textile to Steaming	BDS ISO 105-E 11:2004

D. Electronics and Electrical Products (25 items):

Sl.	Name of the products	Standards No.
116.	Two-Pin Plugs & Socket-Outlets	BDS 102:1990 Reaffirmed 2005
117.	Three-Pin Plugs & Socket-Outlets	BDS 115:1989 Reaffirmed 2005
118.	Aluminium Conductors steel Re-inforced for Overhead Power Transmission	BDS 1037 : 2003
119.	Bare Aluminium and Aluminium alloy Conductors for overhead power transmission	BDS 1036:2006
120.	Winding Wires: a) Part 1 Enameled round copper winding wires b) Part-2 Enameled rectangular copper winding wires c) Part 3 Enameled round Aluminium winding wires d) Part-4 Enameled rectangular Aluminium winding wires e) Part-5 Test Method	BDS 1034 (Part-1):2006 BDS 1034 (Part-2):2006 BDS 1034 (Part-3):2006 BDS 1034 (Part-4):2006 BDS 1034 (Part-5):2006
121.	(a) Insulated Flexible Cords (Part-1) General requirements (b) Insulated Flexible Cords (Part-2) Requirements for rubber insulated flexible cords (C) Insulated Flexible Cords (Part-3) Requirements for PVC Insulated Flexible cords (d) Insulated Flexible Cords (Part-4) Flexible cords Insulated with varnished glass fiber. (e) Insulated Flexible Cords (Part-5) Methods of test. (f) Insulated Flexible Cords (Part-6) Methods of test.	BDS 899 (part-1) :2000 BDS 899 (part-2) :2001 BDS 899 (part-3) :2001 BDS 899 (part-4) :2001 BDS 899 (part-5) :2001 BDS 899 (part-6):2001
122.	Three phase Induction Motors	BDS 1139:1986 Amendment 1:2006
123.	Power Cables with extruded insulation and their accessories for rated voltage from 1kv up to 30kv 1. Part 1 Cables for rated voltage of 1 kv and 3 kv 2. Part-2 Cables for rated voltage from 6kv up to 30 kv	

	3. Part-4 Test requirement of accessories for 6kv up to 30 kv	BDS IEC 60502-1:2005 BDS IEC 60502-2:2005 BDS IEC 60502-4:2005
124.	(a) Lead acid starter batteries (Part-1) General requirements and methods of test. (b) Lead acid starter batteries (Part-2) Dimensions of batteries and dimension and marking of terminals. (c) Lead acid starter batteries (Part-3) Dimension of batteries for heavy commercial vehicles.	BDS 206 (Part-1) :2002 BDS 206 (Part-2) :2002 BDS 206 (Part-3) :2002
125.	Porcelain Insulator for overhead power lines with a nominal voltage Up to and including 1000 V	BDS 1543:2006
126.	Electricity Metering Equipment (AC) –Particular Requirements (Part-11), Electromechanical Meters for Active Energy (Class 0.5.1 and 2)	BDS IEC 62053-11 :2004
127.	Switches for household and similar fixed electrical installation Part-1 General requirement	BDS IEC60669-1:07
128.	Self-Ballasted Lamps for General Lighting Services- Performance Requirements	BDS 1734:2003
129.	Electronic Ballasts for Tubular Fluorescent Lamps- Performance Requirements	BDS IEC 60929:05
130.	Cut-Out Switches (Main Switches)	BDS 1395:1993 Reaffirmed 2005
131.	Ceiling Roses	BDS 116:2006
132.	Electronic Type Fan Regulators	BDS 1323:1991 Amendment 1:2006
133.	Ballast for Tubular Fluorescent Lamps performance requirements	BDS IEC 60921:2005
134.	Electric Irons for household or similar use methods for measuring performance	BDS IEC 60311:05
135.	PVC Insulated Cables (non armoured for electric power and lighting)	BDS 900 : 2000
136.	Tungsten Filament Lamps for domestic and similar general lighting purposes performance requirements	BDS 17:2006
137.	Electric circulating Fans & Regulators (ceiling and deck head fans, pedestal fans & table/cabin fans within built regulators)	BDS 818:1998 Amendment 1: 2006
138.	Primary Batteries: 1. Part-1 General 2. Part-2 Physical and Electrical Specification 3. Part-3 Watch Battery 4. Part 4 Safety and lithium Batteries 5. Part-5 Safety of Batteries with Aquas Electrolyte	BDS IEC 60086-1:2005 BDS IEC 60086-2:2005 BDS IEC 60086-3:2005 BDS IEC 60086-4:2005 BDS IEC 60086-5:2005
139.	Insulators for overhead lines with a nominal voltage over 1000 V 1. Part-1 Ceramic or glass Insulator units for ac systems- definitions, test methods and acceptance criteria 2. Part-2 Insulator strings and insulator sets for ac systems- definition, test methods and acceptance criteria	BDS IEC 600383-1:2006 BDS IEC 600383-2:2006
140.	Double capped Fluorescent Lamps performance requirements	BDS IEC 60081:06

E. Engineering Products (15 items):

Sl.	Name of the products	Standards No.
141.	Mild Steel Pipe and G.I. Pipe	BDS 1031:2006
142.	Protective Helmets for Scooter & Motor Cycle Riders	BDS 1136:1986 Reaffirmed 07
143.	Safety Razor Blades	BDS 219:2002
144.	Sanitary ware appliances	BDS 1162:2006
145.	Pipes and fittings made of un-plasticized polyvinyl chloride (PVC-U) for water supply - Part 1: General - Part 2: Pipes (with or without) integral sockets - Part 3: Fittings and Joints	BDS ISO 4422-1 :2008 BDS ISO 4422-2 :2008 BDS ISO 4422-3:2008
146.	Steel for the Re-enforcement of Concrete (Part-1 & Part-2)	BDS ISO 6935-1:2006 BDS ISO 6935-2:2006

147.	G P Sheet (with Corrugation)	BDS 1122:1987 Reaffirmed 2007
148.	Portable Fire Extinguisher	BDS 825:1991 Reaffirmed 2007
149.	Gas Mantles	BDS 1197:1988 Reaffirmed 2007
150.	Bi-cycle Rim	BDS 986:2006
151.	Bitumen and Bituminous Binders Paving Grade Bitumen Bitumen and Bituminous Binders Cationic Bituminous Emulsions	BDS EN 12591:2009 BDS EN 13808:2009
152.	Cement part 1 Composition, Specifications and Conformity criteria for common Cement	BDS EN 197-1:2003
153.	Common Building Clay Bricks	BDS 208:1980
154.	Ceramic Tiles	BDS ISO 13006:2006
155.	Aluminium and Aluminium alloys-Extruded rod/bar tube and profiles-Profiles, tolerances on dimensions and form.	BDS 1825: 2011

Annex-2: Glossary of Plastic Terminology

Abrasion Resistance: The ability to withstand the effects of repeated wearing, rubbing, scraping, etc., that tend to remove material from its surface.

Accelerator: A substance that hastens a reaction, particularly one which speeds up the vulcanization of rubber. Also known as Promoter.

Accumulator: A term used mainly with reference to blow molding equipment which designates an auxiliary ream extruder which is used to provide extremely fast parison delivery.

Acrylic Resin: A synthetic resin prepared from acrylic acid or from a derivative of acrylic acid,

Acrylonitrile Butadiene Styrene (ABS): Acrylonitrile and styrene liquids and butadiene gas are polymerized together in a variety of ratios to produce the family of ABS resins.

Additive: A substance compounded into a resin to enhance or improve certain characteristics.

Adhesion Promoter: A coating which is applied to the substrate before it is extrusion coated with the plastic and which improves the adhesion of the plastic to the substrate.

Adhesive: A substance which applied as an intermediate is capable of holding materials together by surface attachment.

Aging: The change of a material with time under defined environmental conditions, leading to improvement or deterioration of properties.

Air-assist Forming: A method of thermoforming in which a flow of air pressure is employed to partially pre-form the sheet immediately prior to the final pull down onto the mold using vacuum.

Alkyd Resin: Polyester resins made with some fatty acid as a modifier.

Allyl Resin: A synthetic resin formed by the polymerization of chemical compounds containing the group $\text{CH}_2=\text{CH}-\text{CH}_2-$.

Alpha-cellulose: Very pure cellulose prepared by special chemical treatment.

Amine: Any of a class of organic compounds derived from ammonia by replacement of hydrogen with one or more alkyl groups.

Amorphous Phase: Devoid of crystallinity – no definite order. At processing temperatures, the plastic is normally in the amorphous state.

Annealing: A process of holding a material at a temperature mean, but below its melting point, the objective being to permit stress relaxation without distortion of shape. It is often used on molded articles to relieve stresses set up by flow into the molds.

Anti-friction Compounds: Materials specifically formulated to reduce or eliminate friction.

Antifogger: An additive that prevents condensation of moisture on glass and other transparent materials, such as windshields or lenses.

Antioxidants & Antiozonants: These additives are used to prevent the negative effects of oxygen and ozone on the resin materials.

Antistatic Agents: Methods of minimizing static electricity in plastic materials.

Aramid: Any of a group of lightweight by very strong heat-resistant synthetic aromatic polyamide materials that are fashioned into fibers, filaments, or sheets.

Aromatic Hydrocarbons: Hydrocarbons derived from or characterized by presence of unsaturated resonant ring structures.

Asbestos: A gray, non-burning, non-conductive and chemical resistant material occurring in long fibers or fibrous masses, sometimes used as a filler for reinforcement.

Atactic: A polymer exhibiting no stereochemical regularity of structure.

Autoclave Molding: Modification of the pressure bag method for molding reinforced plastics. After lay-up, entire assembly is placed in steam autoclave at 50 to 100 psi. Additional pressure achieves higher reinforcement loadings and improved removal of air.

Back Pressure: The viscosity resistance of a material to continued flow when a mold is closing. In extrusion, the resistance to the forward flow of molten material.

Backing Plate: In injection molding, a plate used as a support for the cavity blocks, guide pins, bushings, etc.

Baffle: A device used to restrict or divert the passage of fluid through a pipe line or channel.

Bag molding: A method of applying pressure during bonding or molding, in which a flexible cover, usually in connection with a rigid die or mold, exerts pressure on the material being molded, through the application of air pressure or drawing of a vacuum.

Bakelite: The proprietary name for phenolic and other plastics materials produced by Bakelite Limited, but often used indiscriminately to describe any phenolic molding material or molding. The name is derived from that of Dr. Leo Hendrik Baekeland (1863-1944), a Belgian who, through his work on synthesis of phenolic resins and their commercial development in the early 1900's, is generally considered to be the "father" of the plastic industry.

Binder: The organic or inorganic material which encapsulates and holds together the base in reinforced or otherwise heterogeneous composites.

Biocides & Fungicides: These additives act as pesticides and are used to inhibit the growth of fungus and other pests.

Bleed: To give up color when in contact with water or a solvent; undesired movement of certain materials in a plastic (e.g. plasticizers in vinyl) to the surface of the finished article or into an adjacent material. Also called Migration.

Blister: A raised area on the surface of a molding caused by the pressure of gases inside it on its incompletely hardened surface.

Block Copolymer: An essentially linear copolymer in which there are repeated sequences of polymeric segments of different chemical structure.

Blocking & Anticaking Agents: These additives are used to prevent the adhesion of two touching layers of film during fabrication and storage.

Bloom: A visible exudation or efflorescence on the surface of a material.

Blow Molding: Method of fabrication in which a warm plastic parison (hollow tube), is placed between the two halves of a mold cavity and forced to assume the shape of that mold cavity by use of air pressure.

Blow Pressure: The air pressure used to form a hollow part by blow molding.

Blow Rate: The speed at which the air enters the parison during the blow loading cycle.

Blowing & Foaming Agents: Upon addition to plastics or rubbers and then heating, this chemical generates inert gases which results in the resin assuming a cellular structure.

Blowup Ratio: In blow molding, the ratio of the mold cavity diameter to the parison diameter. In blown tubing (film), the ratio of the final tube diameter (before gusseting, if any) to the original die diameter.

Bond Strength: 1) The measure of the force required to separate objects or materials bonded together. 2) The strength of the bond between fiber and matrix. 3) The degree of attraction between adjacent atoms within a molecule, usually expressed in J/mol.

Boss: Protuberance on a plastic part designed to add strength, to facilitate alignment during assembly, to provide for fastening, etc.

Bottom Blow: A specific type of blow molding machine which forms hollow articles by injecting the blowing air into the parison from the bottom of the mold.

Bottom Plate: Part of the mold which contains the heel radius and the push-up.

Branched: In molecular structure of polymers (as opposed to Linear), refers to side chains attached to the main chain. Side chains may be long or short.

Breakdown: The disruptive discharge through insulation due to failure under electrostatic stress.

Breaker Plate: A perforated plate located at the rear end of an extruder head. It often supports the screens that prevent foreign particles from entering the die.

Breathing: The opening and closing of a mold to allow gases to escape early in the molding cycle. Also called Degassing. When referring to plastic sheeting, “breathing” indicates permeability to air.

Brighteners: Are used to add smoother or brighter coatings.

British Thermal Unit (BTU): The quantity of heat required to raise the temperature of one pound of water 1°F from 58.5 to 59.5°F (its point of maximum density).

Bulk Density: The mass per unit volume of a molding powder as determined in a reasonably large volume. The recommended test method is ASTM D1182-54.

Bulk Factor: Ratio of the volume of loose molding powder to the volume of the same weight of resin after molding.

Bulk-molding compounds (BMC): Bulk-molding compounds are used as a premix in composite manufacturing. A BMC consists of a mixture of resin, reinforcements, inert fillers, and other additives which form a puttylike preformed shape, rope or sheet.

Butadiene: A gas, insoluble in water but soluble in alcohol and ether, obtained from the cracking of petroleum, from coal tar benzene or from acetylene produced from coke and lime.

Butadiene Styrene Plastics: A synthetic resin derived from the copolymerization of butadiene gas and styrene liquids.

Buttress Thread: A type of threading in which the thread sides terminate abruptly in threading gradually tapering down to the neck finish.

Butylene Plastics: Plastics based on resins made by the polymerization of butene or copolymerization by butene with one or more unsaturated compounds, the butene being in greatest amount by weight.

Calendering: A form of extrusion using two or more counter rotating rolls in which film and sheet is produced by squeezing a hot, viscous material between them.

Carbon Black: A black pigment produced by the incomplete burning of natural gas or oil. It is widely used as filler, particularly in the rubber industry.

Carbonyl: Organic functional group occurring in aldehydes, ketones, carboxylic acids, esters and their derivatives.

Cast: To form a “plastic” object by pouring a fluid monomer-polymer solution into an open mold where it finishes polymerizing. (2) Forming plastic film and sheet by pouring the liquid resin onto a moving belt or by precipitation in a chemical bath.

Catalyst: A substance which markedly speeds up the cure of a compound when added in minor quantity as compared to the amounts of primary reactants.

Cavity: Depression in a mold made by casting, machining, hobbing, or a combination of these methods; depending on number of such depressions, molds are designated as Single-Cavity or Multi-Cavity.

Cellular Plastics: Plastics containing numerous small cavities (cells), interconnecting or not distributed throughout the mass.

Celluloid: A thermoplastics material made by the intimate blending of cellulose nitrate with camphor.

Cellulose: A natural high polymeric carbohydrate found in most plants; the main constituent of dried woods, jute, flax, hemp, ramie, etc. Cotton is almost pure cellulose.

Cellulose Propionate: An ester of cellulose made by the action of propionic acid and its anhydride on purified cellulose. It is used as the basis of a thermoplastic molding material.

Cellulose Triacetate: A cellulosic material made by reacting purified cellulose with acetic anhydride in the presence of a catalyst.

Celsius: Also referred to as Centigrade, is equal to the difference between the temperature in Fahrenheit less 32 and the quantity divisible by 1.8°C = (°F – 32) ÷ 1.8.

Cement: A dispersion of “solution” of unvulcanized rubber or a plastic in a volatile solution. This meaning is peculiar to plastics and rubber industries and may not be an adhesive composition.

Center Gated mold: An injection mold wherein the cavity is filled with resin through an orifice interconnecting the nozzle and the center of the cavity area. Normally, this orifice is located at the bottom of the cavity when forming items such as containers, tumblers, bowls, etc.

Centrifugal Casting: A method of forming thermoplastic resins in which the granular resin is placed in a rotatable container, heated to molten condition by the transfer of heat through the walls of the container, and rotated so that the centrifugal force induced will force the molten resin to conform to the configuration of the interior surface of the container.

Charge: The measurement or weight of material used to load a mold at one time or during one cycle.

Chlorinated Polyvinyl Chloride Plastics: Plastics based on chlorinated polyvinyl chloride in which the chlorinated polyvinyl chloride is in the greatest amount of weight.

Chlorofluorocarbon Plastics: Plastics based on polymers made with monomers composed of chlorine, fluorine, and carbon only.

Clamping Plate: A plate fitted to a mold and used to fasten the mold to a molding machine.

Clamping Pressure: In injection molding and in transfer molding, the pressure which is applied to the mold to keep it closed, in opposition to the fluid pressure of the compressed molding material.

Clarifier: An additive that increases the transparency of a material.

Co-extrusion: The process of combining two or more layers of extrudate to produce a multiple layer product in a single step.

Coalesce: To combine into one body or to grow together.

Coefficient of Expansion: The fractional change in length (sometimes volume, specified) of a material for a unit change in temperature. Values for plastics range from 0.01 to 0.2 mils/in., C

Coefficient of Friction: Static: the ration of the limiting friction developed to the corresponding normal pressure if two surfaces move relative to each other.

Coefficient of Thermal Expansion: The unit change in dimension of a material for a unit change in temperature.

Colorants & Pigments: Are additive used to change the color of the plastic. They can be a powder or a resin/color premix.

Composite: 1) A structure or an entity made up of distinct components. 2) A complex material, such as fiberglass, in which two or more distinct, structurally complementary substances, especially glasses and polymers, combine to produce structural or functional properties not present in any individual component. 3) Reinforced laminates (i.e., canvas phenolic, glass epoxy, etc.).

Compound: These are chemical combinations of materials which include all the materials necessary for the finished product. They include BMC (Bulk Molding Compounds), SMC (Sheet Molding Compounds) and TMC (Thick Molding Compounds).

Compression Molding: The process of molding a material in a confined shape by applying pressure and usually heat.

Compression Ratio: In an extruder screw, the ratio of volume available in the first flight at the hopper to the last flight at the end of the screw.

Compressive Strength: The ability of a material to resist a force that tends to crush it.

Condensation: A chemical reaction in which two or more molecules combine with the separation of water or some other simple substance.

Conditioning: The subjection of a material to a stipulated treatment so that it will respond in a uniform way to subsequent testing or processing.

Continuous Service Temperature: The highest temperature at which a material can perform reliably in long term application – long term being, however, inconsistently defined by the manufacturers.

Convergent Die: A die in which the internal channels leading to the orifice are converging (only applicable to dies for hollow bodies).

Copolymer: The chemical reaction of two different monomers with each other, result in a compound.

Core: The central member of any assembly.

Corrosion: Chemical action which causes destruction of the surface of a material by oxidation or chemical combination.

Corrosion Resistance: The ability to withstand the effect of oxidation.

Coupling Agents: A material that is used to form a chemical bridge between the resin and glass fiber or mineral fiber. By acting as an interface, bonding is enhanced.

Crater: A small, shallow surface imperfection.

Crazing: Small cracks near or on the surface of plastic materials.

Creep: The dimensional change with time of a material under load. At room temperature it is also called cold flow.

Cross Laminate: A laminate in which some of the layers of material are oriented approximately at right angles to the remaining layers with respect to the grain or strongest direction in tension.

Cross-linking: The formation of chemical links between the molecular chains in polymers. This process can be achieved by chemical reaction, vulcanization, and electron bombardment.

Crosshead (extrusion): A device generally employed in wire coating which is attached to the discharge end of the extruder cylinder, designed to facilitate extruding material at an angle.

Crystallinity: A molecular structure resulting from the formation of solid crystals with a geometric pattern.

Cull: Material remaining in a transfer chamber after mold has been filled.

Cure: The process of changing properties of polymer into a more stable and usable condition. This is accomplished by the use of heat, radiation, or reaction with chemical additives.

Cure Cycle: The time periods at defined conditions to which a reacting thermosetting material is processed to reach a desired property level.

Curing Temperature: Temperature at which a cast, molded, or extruded product, a resin-impregnated reinforcing material, an adhesive, etc., is subjected to curing.

Curing Time: The period of time that a reacting thermosetting material is exposed to specific conditions to reach a specified property level.

Curtain Coating: A method of coating which may be employed with low viscosity resins or solutions, suspensions, or emulsions of resins in which the substrate to be coated is passed through and perpendicular to a freely falling liquid “curtain” (or “waterfall”).

Cut-off: The line where the two halves of a compression mold come together; also called Flash Groove or Pinch-off.

Dash-pot: A device used in hydraulic systems for damping down vibration.

Daylight Opening: Clearance between two platens of a press in the open position.

Deckle Rod: A small rod, or similar device, inserted at each end of the extrusion coating die which is used to adjust the length of the die opening.

Deflashing: Covers the range of finishing techniques used to remove the flash (excess, unwanted material) on a plastic molding.

Deflection Temperature: The measure of temperature at which a specimen deflects 0.01 inches under a load of 264 lb/in².

Degree of Polymerization: The number of structural units or mers in the “average” polymer molecule in a particle sample. In most plastics the DP must reach several thousand if worthwhile physical properties are to be had.

Delamination: The separation of a laminate along the plane of its layers. Also the separation of bonded insulation within the adhesive layer or at the adhesive interface.

Deliquescent: Capable of attracting moisture from the air.

Desiccant: Substance which can be used for drying purposes because of its affinity for water

Die Gap: The distance between the metal faces forming the die opening.

Die Lines: Vertical marks on the parison caused by damage of die parts or contamination.

Die Swell Ratio: The ratio of the outer parison diameter (or parison thickness) to the outer diameter of the die (or die gap).

Dielectric: 1) Any insulating medium which intervenes between two conduits and permits electrostatic attraction or repulsion to take place across it. 2) A material having the property that energy required to establish an electric field is recoverable in whole or in part, as electric energy (see insulation for clarification).

Dielectric Constant: The ratio of the capacity of a condenser made with a particular dielectric material to the capacity of the same condenser with air as the dielectric. Measured at a frequency of 106 cycles per second.

Dielectric Constant (Permittivity or Specific Inductive Capacity): The specific inductive capacity of a dielectric. That property of a dielectric which determines the electrostatic energy stored per unit volume for unit potential gradient.

Dielectric Heating (Electronic Heating): The plastic to be heated forms the dielectric of a condenser to which is applied a high-frequency (20 to 80 mc.) voltage.

Dielectric Strength: The voltage that an insulating material can withstand before dielectric breakdown occurs.

Dip Coating: Applying a plastic coating by dipping the article to be coated into a tank of melted resin or plastisol, then chilling the adhering melt.

Discoloration: Any change from the original color, often caused by overheating, light exposure, irradiation, or chemical attack.

Dispersion: Finely divided particles of a material in suspension in another substance.

Divergent Die: A die in which the internal channels leading to the orifice are diverging (applicable only to dies for hollow bodies).

Double-shot molding: A means of turning out two-color parts in thermoplastics materials by successive molding operations.

Draft: The degree of taper of a side wall or the angle of clearance designed to facilitate removal of parts from a mold.

Drape Assist Frame: In sheet thermoforming, a frame (made up of anything from thin wires to thick bars) shaped to the peripheries of the depressed areas of the mold and suspended above the sheet to be formed. During forming, the assist frame drops down, drawing the sheet tightly into the mold and thereby preventing webbing between high areas of the mold and permitting closer spacing in multiple molds.

Drape Forming: Method of forming thermoplastic sheet in which the sheet is clamped into a movable frame, heated, and draped over high points of a male mold. Vacuum is then pulled to complete the forming operation.

Draw Down Ratio: The ratio of the thickness of the die opening to the final thickness of the product.

Drawing: The process of stretching a thermoplastic sheet or rod to reduce its cross-sectional area.

Ductility: The extent to which a solid material can be drawn into a thinner cross section.

Dwell: A pause in the application of pressure to a mold, made just before the mold is completely closed, to allow the escape of gas from the molding material.

Dyes: Synthetic or natural organic chemicals that are soluble in most common solvents. Characterized by good transparency, high tinctorial strength, and low specific gravity.

Ejector Pin (on Sleeve): A pin or thin plate that is driven into a mold cavity from the rear as the mold opens, forcing out the finished pieces. Also Knockout Pin.

Elastic Deformation: The part of the deformation of an object under load which is recoverable when the load is removed.

Elastomer: A material which at room temperature stretches under low stress to at least twice its length and snaps back to the original length upon release of stress. See also Rubber.

Electroformed Molds: A mold made by electroplating metal in the reverse pattern on the cavity. Molten steel may be then sprayed on the back of the mold to increase its strength.

Electronic Treating: A method of oxidizing a film of polyethylene to render it printable by passing the film between the electrodes and subjecting it to a high voltage corona discharge.

Electroplating: The deposition of a layer of metal on a base of metal or conducting surface by electrolysis.

Embossing: Techniques used to create depressions of a specific pattern in plastics film and sheeting.

Emulsion: A suspension of fine droplets of one liquid in another.

Encapsulating: Enclosing an article (usually an electronic component or the like) in a closed envelope of plastic, by immersing the object in a casting resin and allowing the resin to polymerize or, if hot, to cool.

Epoxy Resins: Straight-chain thermosetting resins containing at least one three-membered ring consisting of two carbon atoms and one oxygenation.

Ester: The reaction product of an alcohol and an acid.

Ethylene Plastics: Plastics based on polymers of ethylene or copolymers of ethylene with other monomers, the ethylene being in greatest amount by mass.

Ethylene-vinyl Acetate: Copolymers from these two monomers form a new class of plastic materials.

Extender: A material added to a plastic compound used to reduce the amount of resin required per unit value.

Extrudate: The product or material delivered by an extruder, such as film, pipe, the coating on wire, etc.

Extrusion: The process of forming a continuous piece of plastic by forcing it through a shaping orifice with or without the presence of heat.

Fabricating: The manufacture of plastic products by appropriate operations. This includes plastics formed into molded parts, rods, tubes, sheeting, extrusion and other forms by methods including punching, cutting, drilling, tapping, fastening or by using other mechanical devices.

Fahrenheit: Equals 1.8 multiplied to the sum of the temperature in Celsius and $^{\circ}\text{F} = 1.8 \times (^{\circ}\text{C} + 32)$.

Family Mold (injection): A multi-cavity mold where each of the cavities forms one of the component parts of the assembled finished object.

Fiber: A thread or threadlike structure such as cellulose, wool, silk or glass yarn.

Filament: 1) Fiber characterized by extreme length. 2) The resistance wire through which filament current is sent in a thermionic tube to produce the heat required for electron emissions.

Filament Winding: Resin impregnated robbing or single strands of glass or other reinforcement wound in a pre-determined pattern onto a suitable form or mandrel and then cured.

Filler: A cheap, inert substance added to a plastic to make it less costly. Fillers may also improve physical properties, particularly hardness, stiffness, and impact strength. The particles are usually small, in contrast to those of reinforcements but there is some overlap between the function of the two.

Fillers & Reinforcements: Fillers are used to make a resin less costly. They can be inert or they can alter some properties of the plastic. Reinforcements are substances used to strengthen or give dimensional stability to a material.

Fillet: A rounded filling of the internal angle between two surfaces of a plastic molding.

Film: Films are flat materials that are extremely thin in comparison to its length and breadth. Typically, a film has a maximum nominal thickness of 0.25 millimeters.

Fin: The web of material remaining in holes or openings in a molded part which must be removed in finishing.

Fish Eye: A fault in transparent or translucent plastics materials, such as film or sheet, appearing as a small globular mass and caused by incomplete blending of the mass with surrounding materials.

Flake: Used to denote the dry, unplasticized base of cellulosic plastics.

Flame Retardant Resin: A resin which is compounded with certain chemicals to reduce or eliminate its tendency to burn. For polyethylene and similar resins, chemicals such as antimony trioxide and chlorinated paraffins are useful.

Flame Spraying: Method of applying a plastic coating in which finely powdered fragments of plastic, together with suitable fluxes, are projected through a cone of flame onto a surface.

Flash: Extra plastic attached to a molding along the parting line; it must be removed before the part can be considered finished.

Flexible Molds: Molds made of rubber or elastomeric plastics used for casting plastics. They can be stretched to remove cured pieces with undercuts.

Flocking: A method of coating by spraying finely dispersed powders or fibers.

Flow Line: A mark on a molded piece made by the meeting of two flow fronts during molding. Also called weld line.

Flow Marks: Wavy surface appearance of an object molded from thermoplastic resins caused by improper flow of the resin into the mold.

Fluidized Bed Coating: A method of applying a coating of a thermoplastic resin to an article in which the heated article is immersed in a dense-phase fluidized bed of powdered resin and thereafter heated in an oven to provide a smooth, pin-hole-free coating.

Fluorocarbon Plastics: Plastics based on polymers made with monomers composed of fluorine and carbon only.

Foaming Agents: Chemicals added to plastics and rubbers that generate inert gases on heating, causing the resin to assume a cellular structure.

Force Plate: The plate that carries the plunger of force plug of a mold and guide pins and bushings. Since it is usually drilled for steam or water lines, it is also called the Steam Plate.

Formaldehyde: A colorless gas (usually employed as a solution in water) which possesses a suffocating, pungent odor.

Furan Resins: Dark colored, thermosetting resins available primarily as liquids ranging from low-viscosity polymers to thick, heavy syrups.

Gasket: Piece used to make a joint fluid-tight.

Gate: In injection and transfer molding, the orifice through which the melt enters the cavity.

Gaylord: A large corrugated container usually sized to match the length and width dimensions of a pallet.

Glass Fiber: Glass in fibrous form that has cooled to a rigid condition without crystallizing.

Gloss: The shine or luster of the surface of a material.

Grit Blasted: A surface treatment of a mold in which steel grit or sand materials are blown to the walls of the cavity to produce a roughened surface.

Guide Pins: Devices that maintain proper alignment of force plug and cavity as mold closes.

Heat Stabilizers: These additives increase the ability of the material to withstand the negative effects of heat exposure. They are used to increase the overall service temperature of the material.

Homopolymer: A polymer, consisting of (neglecting the ends, branch junctions, and other minor irregularities) a single type of repeating unit.

Honeycomb: Manufactured product consisting of sheet metal or a resin impregnated sheet material (paper, fibrous, glass, etc.) which has been formed into hexagonal-shaped cells.

Hopper: Conical feed reservoir into which molding powder is loaded and from which it falls into a molding machine or extruder, sometimes through a metering device.

Hot Gas Welding: A technique of joining thermoplastic materials (usually sheet) whereby the materials are softened by a jet of hot air from a welding torch, and joined together at the softened points.

Hot-runner mold: A mold in which the runners are insulated from the chilled cavities and are kept hot.

Hot-stamping: Engraving operation for marketing plastics in which roll leaf is stamped with heated metal dies onto the face of the plastics.

Hydrolysis: Chemical decomposition of a substance involving the addition of water.

Hygroscopic: Tending to absorb moisture.

Immiscible: Descriptive of two or more fluids which are not mutually soluble.

Impregnate: 1) To fill the voids and interstices of material with a compound (this does not imply complete fill or complete coating of the surfaces by a hole-free film). 2) The process of thoroughly soaking a material of an open or porous nature with a resin.

Impregnation: The process of thoroughly soaking a material such as wood, paper or fabric, with a synthetic resin so that the resin gets within the body of the material.

Impulse Sealing: A heat sealing technique in which a pulse of intense thermal energy is applied to the sealing area for a very short time, followed immediately by cooling.

Inert: Deficient in active properties; not affecting other substances when in contact with them such as inert gases not participating in any fashion in chemical reactions

Infra-red: Part of the electromagnetic spectrum between the visible light range and the radar range. Radiant heat is in this range, and infra-red heaters are used in sheet thermoforming.

Inhibitor: A substance that slows down chemical reaction. Inhibitors are sometimes used in certain types of monomers and resins to prolong storage life.

Injection Molding: The process of forming a material by forcing it from a heated cylinder, under pressure, through a spruce into a cavity of a confined mold.

Insulation: Material having a high resistance to the flow of electric current, to prevent leakage of current from a conductor.

Ionomer Resins: A polymer which has ethylene as its major component, but containing both covalent and ionic bonds. The polymer exhibits very strong interaction ionic forces.

ISO: International Organization of Standardization.

Isomer: One of two or more compounds, radicals or ions that contain the same number of atoms of the same elements by differ in structural arrangement and properties.

Jacket: A tough sheath to protect an insulated wire or cable, or to permanently group two or more insulated wires or cables.

Jet molding: Processing technique characterized by the fact that most of the heat is applied to the material as it passes through the nozzle or jet, rather than in a heating cylinder as is done in conventional processes.

Jetting: Turbulent flow of resin from an undersized gate or thin section into a thicker mold section, as opposed to laminar flow of material progressing radially from a gate to the extremities of the cavity.

Kelvin: The absolute temperature scale (metric). $K = ^\circ C + 273$.

Kirksite: An alloy of aluminum and zinc used for the construction of blow molds; it imparts high degree of heat conductivity to the mold.

Kiss-roll Coating: This roll arrangement carries a metered film of coating to the web; at the line of web contact, it is split with part remaining on the roll, the remainder of the coating adhering to the web.

L/D Ratio: A term used to define an extrusion screw which denotes the ratio of the screw length to the screw diameter.

Laminate: 1) (v) – To build up to desired shape or thickness. 2) (n) – A material composed of successive layers of material, usually bonded together under heat and pressure.

Lattice Pattern: In reinforced plastics, a pattern of filament winding with a fixed arrangement of open voids.

Leach: To extract a soluble component from a mixture by the process of percolation.

Light, UV Stabilizers & Absorbers: These additives increase the ability of the material to withstand the negative effects of light and UV exposure, thus increasing the service life of the material.

Lubricant: Internal lubricants, without affecting the fusion properties of a compound, promotes resin flow.

Luminescent Pigments: Special pigments available to produce striking effects in the dark.

Machine Shot Capacity: Refers to the maximum weight of thermoplastic resin which can be displaced or injected by the injection ram in a single stroke.

Manifold: A term used mainly with reference to blow molding and sometimes with injection molding equipment.

Melamine Plastics: Thermosetting plastics made from melamine and formaldehyde resins.

Melt Flow: Rate of extrusion of molten resin through a die of specified length and diameter.

Mold Release Agent: A lubricant used to coat a mold cavity to prevent adhesion of the molded piece when removed.

Moldability: The characteristics of being easy to mold without rupturing or developing flaws due to movement of the polymer during gelation.

Nylon: The generic name for all synthetic fiber-forming polyamides; they can be formed into monofilaments and yarns characterized by great toughness, strength and elasticity, high melt point, and good resistance to water and chemicals. The material is widely used for bristles in industrial and domestic brushes, and for many textile applications; it is also used in injection molding gears, bearings, combs, etc.

Odorants & Deodorants: Odorants are used to add odor to materials, usually for safety reasons.

Offset: A printing technique in which ink is transferred from a bath onto the raised surface of the printing plate by rollers. Subsequently, the printing plates transfer the ink to the object to be printed.

Outgassing: To remove occluded gases by heating.

Overcoating: In extrusion coating, the practice of extruding a web beyond the edge of the substrate web.

Parison: The hollow plastic tube from which a container, toy, etc. is blow molded.

Parting Agent: A lubricant, often wax, used to coat a mold cavity to prevent the molded piece from sticking to it, and thus to facilitate its removal from the mold. Also called Release Agent.

Phenolic Resin: 1) A synthetic resin produced by the condensation of phenol with an aldehyde (usually formaldehyde). 2) Any of several types of thermoset plastics obtained by the condensation of phenol or substituted phenols.

Pigment: Any colorant, usually an insoluble powdered substance used to produce a desired color of hue.

Plasticizer: Are usually low-melting solids or high-boiling organic liquids which, when added to hard plastics, impart flexibility. They have varying degrees of softening action and solvating ability resulting from a reduction of intermolecular forces in the polymer.

Plastisol: Mixtures of plasticizers and resins which can be converted to continuous films by applying heat.

Plug Forming: A thermoforming process in which a plug or male mold is used to partially preform the part before forming is completed using vacuum or pressure.

Polyester: A resin formed by the reaction between a dibasic acid and a dihydroxy alcohol, both organic. Modification with multi-functional acids and/or bases and some unsaturated reactants permit cross-linking to thermosetting resins. Polyesters modified with fatty acids are called Alkyds.

Polyimide Resins: A new group of resins recently introduced in the United States. The material is an aromatic polyimide made by reacting pyromellitic dianhydride with aromatic diamines.

Polyolefin: A polymer prepared by the polymerization of an Olefin(s) as the sole Monomer(s).

www.smef.org.bd

Small & Medium Enterprise Foundation

Royal Tower, 4 Panthapath, Dhaka-1215, Bangladesh
Phone: +88 02 8142983, 9142907, Fax: +88 02 814344